

TOOLING-LINE

Burins intérieurs en métal dur
 Vollhartmetall Innendrehwerkzeuge
 Solid carbide internal turning tools

1600 / 2620

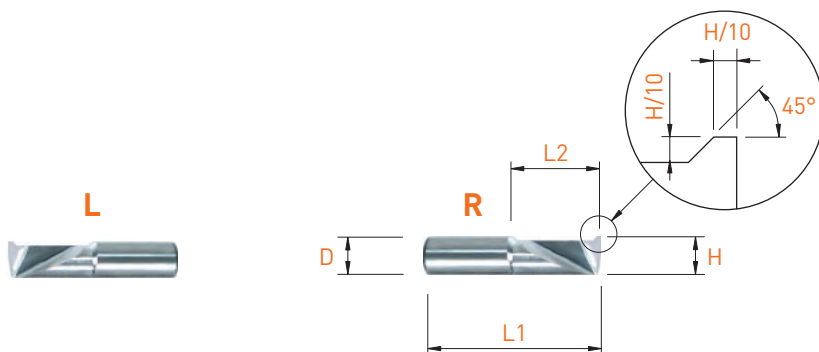

				L	R
				Art. N°	Art. N°
MD VHM HM	H 0/-0.05	D	L1	L2	
	2	3	13	4	1600-2-4 2620-2-4
	3	3	15	6	1600-3-6 2620-3-6
	4	4	17	8	1600-4-8 2620-4-8
	4	4	21	12	1600-4-12 2620-4-12
	5	5	21	10	1600-5-10 2620-5-10
	5	5	26	15	1600-5-15 2620-5-15
	6	6	25	12	1600-6-12 2620-6-12
	6	6	31	18	1600-6-18 2620-6-18
	8	8	32	16	1600-8-16 2620-8-16
	8	8	40	24	1600-8-24 2620-8-24

Burins intérieurs en métal dur
 Vollhartmetall Innendrehwerkzeuge
 Solid carbide internal turning tools

1610 / 2630

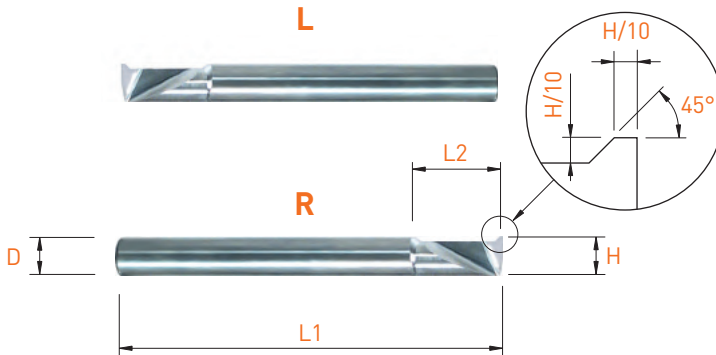

MD VHM HM				L	R
H 0/-0.05	D	L1	L2	Art. N°	Art. N°
2	3	38	4	1610-2-4	2630-2-4
3	3	38	6	1610-3-6	2630-3-6
4	4	40	8	1610-4-8	2630-4-8
4	4	40	12	1610-4-12	2630-4-12
5	5	50	10	1610-5-10	2630-5-10
5	5	54	15	1610-5-15	2630-5-15
6	6	50	12	1610-6-12	2630-6-12
6	6	57	18	1610-6-18	2630-6-18
8	8	58	16	1610-8-16	2630-8-16
8	8	63	24	1610-8-24	2630-8-24
10	10	72	30	-	2630-10-30
12	12	83	36	-	2630-12-36