

INFO	Codification Bezeichnungsschlüssel Designation key	Paramètres de coupe indicatifs Empfohlene Schnittwerte Standard machining data	Nuances Sorten Grades > 3.02
SERIES 630 / 640 Tournage et gorge Drehen und Einstechen Turning and grooving	Porte-outils Halter Holders	 630 / 640	> 3.06
	Tournage avant Vorwärts drehen Front turning	632 / 642	 > 3.08
	Tournage arrière Rückwärts drehen Back turning	633 / 643	 > 3.11
	Fonçage-tournage Einstechen und drehen Grooving and turning	634 / 644	 > 3.19
	Chanfreinage Anfasen Chamfering	635 / 645	 > 3.24
	Filetage Gewinde drehen Threading	636 / 646	 > 3.26
	Plaquettes à rayon Radius Wendepplatten Radius inserts	637 / 647	 > 3.28
	Plaquettes ébauches WSP-Rohlinge Blank inserts	631-EP / 641-EP	 > 3.30
	SERIES 650 / 660 Tronçonnage Abstechen Parting off	Porte-outils Halter Holders	 650 / 660
Tronçonnage Abstechen Parting off		651 / 661	 > 3.34
Tronçonnage - coupe déportée Abstechen - versetztes Schneiden Parting off - cut off line		651R	 > 3.39
Plaquettes ébauches WSP-Rohlinge Blank inserts		651-EP / 661-EP	 > 3.44
Pièces de rechange et accessoires Ersatzteile und Zubehör Spare parts and accessories			> 3.45

642

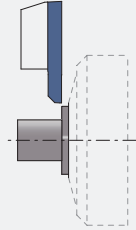

643

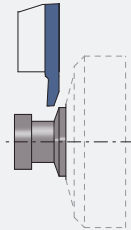

644

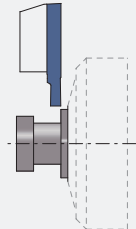

645

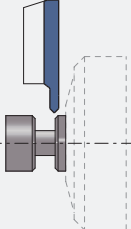

646

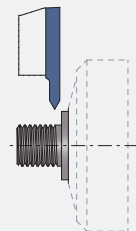

647

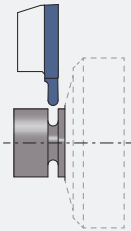

661

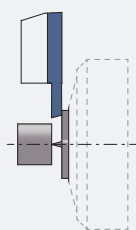

651R

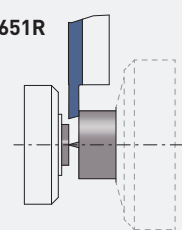

Codification des plaquettes PRO-Line série 600

WSP-Bezeichnungssystem für PRO-Line 600 Serie

Inserts designation key for PRO-Line 600 series

INFO



Dimension
Abmessung
Dimension

Rayon
Radius
Radius

Nuance
Sorte
Grade

Géométrie de coupe
Schneidgeometrie
Cutting geometry

brise-copeau
Spanbrecher
chip breaker

particularités
Sondereigenschaften
special features

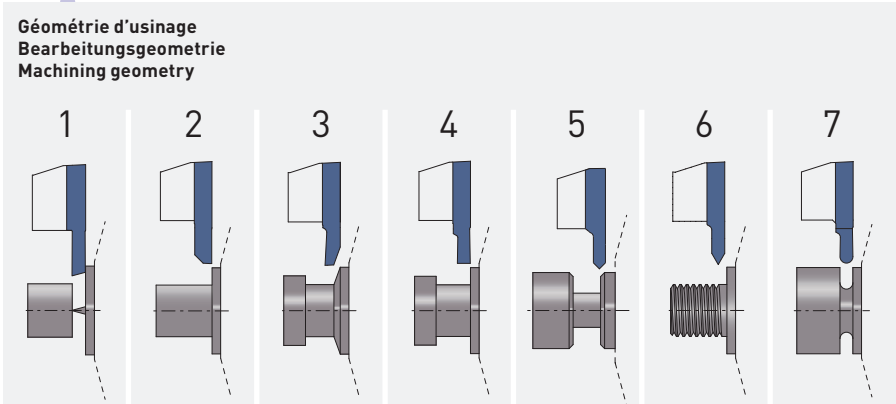

Gamme de produit
Produktserie
Product series

définit la compatibilité des plaquettes avec le porte-outil
bestimmt die WSP und Halter Kompatibilität
shows the inserts and holder compatibility

L = 3, 5 (chiffre impair / ungerade Zahl / uneven number)

R = 4, 6 (chiffre pair / gerade Zahl / even number)

SERIES

Tournage
et gorge

Drehen und
Einstechen
Turning and
grooving

W max = 3 mm
L max = 8 mm

L R
630 640

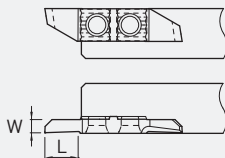

SERIES

Tronçonnage
Abstechen
Parting off

W max = 2.5 mm
L max = 11 mm

L R
650 660

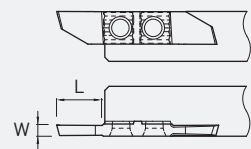

Applitec série 600
Applitec 600 Serie
Applitec 600 series

Système de serrage à denture avec 2 vis de fixation
Spannsystem mit Verzahnung und 2 Schrauben
Teeth clamping system with 2 screws

Paramètres de coupe indicatifs

Empfohlene Schnittwerte

Standard machining data

Matière Werkstoff Material	Tournage Drehen Turning			Tronçonnage Abstechen Parting off		
	VC	630/640		VC	650/660	
		Prof. de passe Schnitttiefe Depth of cut	Avance Vorschub Feed		Largeur de coupe Abstechbreite Cutting width	Avance Vorschub Feed
(m/min)	(mm)	(mm/U)	(m/min)	(mm)	(mm/U)	
Acier de décolletage Automatenstahl Free-cutting steel	P 120 - 200	0.05 - 1.0 1.0 - 4.0	0.01 - 0.15 0.05 - 0.25	80 - 150	0.50 - 1.50 1.50 - 2.50	0.01 - 0.08 0.03 - 0.15
Acier Stahl < 600 N/mm ² Steel	P 80 - 160	0.05 - 1.0 1.0 - 4.0	0.01 - 0.15 0.05 - 0.25	70 - 120	0.50 - 1.50 1.50 - 2.50	0.01 - 0.06 0.03 - 0.12
Acier Stahl < 800 N/mm ² Steel	P 60 - 120	0.05 - 1.0 1.0 - 4.0	0.01 - 0.10 0.05 - 0.20	60 - 100	0.50 - 1.50 1.50 - 2.50	0.01 - 0.05 0.03 - 0.10
Acier Stahl > 800 N/mm ² Steel	P 50 - 100	0.05 - 1.0 1.0 - 3.0	0.01 - 0.08 0.05 - 0.15	40 - 80	0.50 - 1.50 1.50 - 2.50	0.01 - 0.04 0.03 - 0.08
Acier inoxydable Rostfreistahl Stainless steel	M 60 - 120	0.05 - 1.0 1.0 - 3.0	0.01 - 0.08 0.05 - 0.15	60 - 100	0.50 - 1.50 1.50 - 2.50	0.01 - 0.04 0.03 - 0.08
Aluminium Si <12%	N 200 - 1000	0.05 - 1.0 1.0 - 4.0	0.01 - 0.20 0.05 - 0.40	180 - 400	0.50 - 1.50 1.50 - 2.50	0.01 - 0.10 0.03 - 0.20
Aluminium Si >12%	N 180 - 800	0.05 - 1.0 1.0 - 4.0	0.01 - 0.20 0.05 - 0.40	150 - 300	0.50 - 1.50 1.50 - 2.50	0.01 - 0.10 0.03 - 0.20
Cuivre, laiton, bronze Kupfer, Messing, Bronze Copper, brass, bronze	N 100 - 500	0.05 - 1.0 1.0 - 4.0	0.01 - 0.20 0.05 - 0.35	100 - 300	0.50 - 1.50 1.50 - 2.50	0.01 - 0.10 0.03 - 0.20
Titane Titan Titanium	S 30 - 70	0.05 - 1.0 1.0 - 4.0	0.01 - 0.08 0.05 - 0.15	30 - 50	0.50 - 1.50 1.50 - 2.50	0.01 - 0.03 0.03 - 0.06

Nuances

Sorten

Grades

TiAlN

μK20 + revêtement PVD
μK20 + PVD Beschichtung
μK20 + PVD coating

- excellente nuance universelle
- 1^{er} choix pour l'usinage des aciers, aciers inoxydables et alliages de titane
- très bonne résistance à la température

- beste Universalsorte
- für die Bearbeitung von Stahl, rostfreiem Stahl und Titanlegierungen bestens geeignet
- sehr gute Warmfestigkeit

- best universal grade
- first choice for steel, stainless steel and titanium alloys machining
- very good heat resistance

N (μK20)

non revêtu
unbeschichtet
uncoated

- nuance micro-grain tenace
- supporte les coupes interrompues et autres conditions d'usinage défavorables

- zähe Feinkornsorte
- für unterbrochene Schnitte und andere ungünstige Bearbeitungsbedingungen geeignet

- tough micro-grain grade
- suitable for interrupted cut and other unfavorable machining conditions

HTA

μK10 + revêtement PVD
μK10 + PVD Beschichtung
μK10 + PVD coating

- nuance très résistante à l'usure
- pour l'usinage en finition dans des conditions favorables des aciers, aciers inoxydables et alliages de titane

- sehr verschleissfeste Sorte
- für die Feinbearbeitung von Stahl, rostfreiem Stahl und Titanlegierungen bei guten Bearbeitungsbedingungen

- very wear resistant grade
- for light machining of steel, stainless steel and titanium alloys under favorable machining conditions

HN (μK10)

non revêtu
unbeschichtet
uncoated

- nuance micro-grain très résistante à l'usure
- recommandé pour l'usinage du titane faiblement allié
- déconseillé en cas de coupe interrompue et autres conditions d'usinage défavorables

- verschleissfeste Feinkornsorte
- für die Bearbeitung von niedrig legiertem Titan empfehlenswert
- für unterbrochene Schnitte und andere ungünstige Bearbeitungsbedingungen nicht geeignet

- wear resistant micro-grain grade
- suitable for the machining of low alloyed titanium
- not suitable for interrupted cut and other unfavorable machining conditions

L

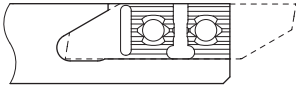

R

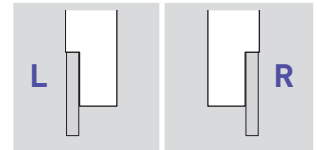
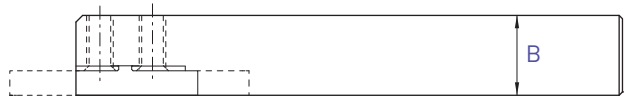
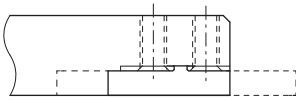
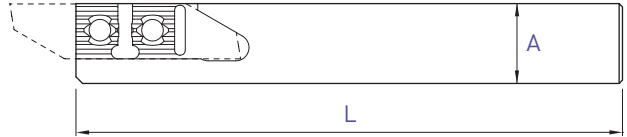

A x B	L	Art. N°	Art. N°
8 x 8	115	630-8	640-8
10 x 10	115	630-10	640-10
10 x 10	50	630-10-50	640-10-50
12 x 12	130	630-12	640-12
12 x 12	90	630-12-90	640-12-90
12.7 x 12.7	130	630-12.7	640-12.7
16 x 16	130	630-16	640-16
16 x 16	75	630-16-75	640-16-75
20 x 20	120	630-20	640-20

Chaque support est livré avec vis et clé.
 Jeder Halter wird mit Spannschraube(n) und Schlüssel geliefert.
 Screw(s) and key are included with each tool holder.

Porte-outils avec arrosage intégré
 Halter mit integrierter Kühlmittelzufuhr
 Holders with integrated coolant supply

630-JET / 640-JET

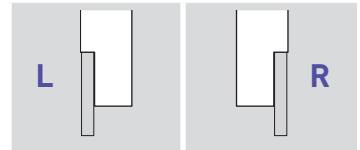
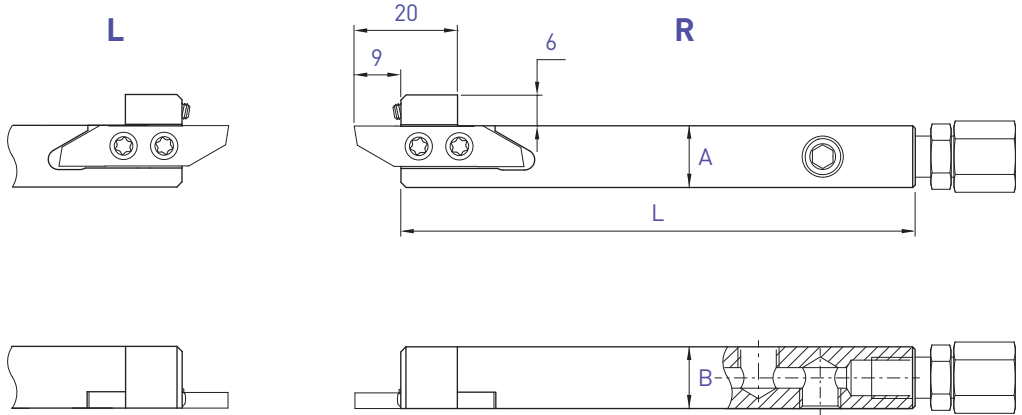

A x B	L	Art. N°	Art. N°
10 x 12	100	630-1012-JET	640-1012-JET
12 x 12	100	630-12-JET	640-12-JET
12.7 x 12.7	100	630-12.7-JET	640-12.7-JET
16 x 16	100	630-16-JET	640-16-JET
20 x 20	100	630-20-JET	640-20-JET

Chaque support est livré avec vis, clé, raccord droit et buse d'arrosage Ø 1.5 mm.
 Jeder Halter wird mit Spannschraube(n), Schlüssel, gerader Kühlmittelanschluss und Kühlmitteldüse Ø 1.5 mm geliefert.
 Screw(s), key, straight connector and coolant nozzle Ø 1.5 mm are included with each tool holder.

PRO-LINE

Tournage avant
Vorwärts drehen
Front turning

632 / 642

L

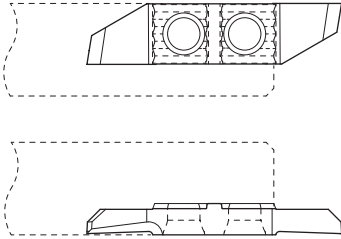

R

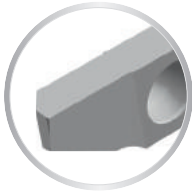
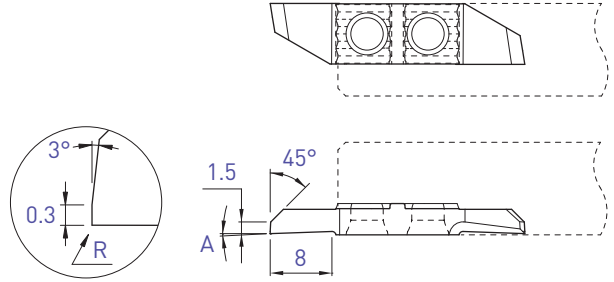

L



R



A	R	Art. N°	TiAlN N [µk20]	HTA HN [µk10]	Art. N°	TiAlN N [µk20]	HTA HN [µk10]
0°	0	632	■ ■		642	■ ■	□ □
0°	0.08	-			642-R08	■ ■	□ □
0°	0.15	-			642-R15	■ ■	□ □
2°	0	632-2°	■ ■		642-2°	■ ■	□ □
2°	0.08	-			642-2°-R08	■ ■	□ □
2°	0.15	-			642-2°-R15	■ ■	□ □

Tournage avant
Vorwärts drehen
Front turning

632X / 642X

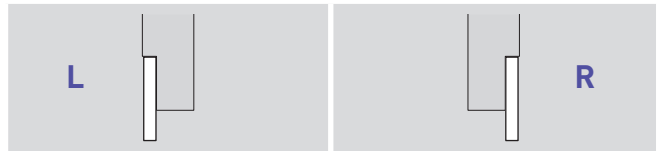
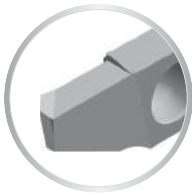
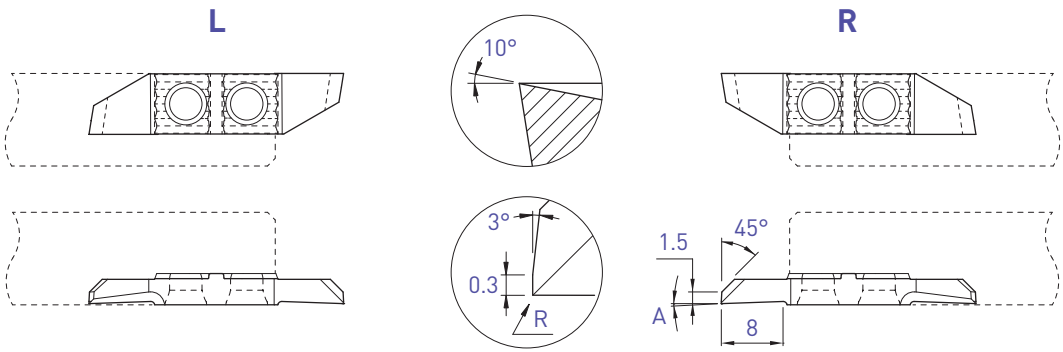

A	R	Art. N°	TiAlN N [µk20]	HTA HN [µk10]	Art. N°	TiAlN N [µk20]	HTA HN [µk10]
0°	0	632X10	■ ■		642X10	■ ■	□ □
0°	0.08	-			642X10-R08	■ ■	□ □
0°	0.15	-			642X10-R15	■ ■	□ □
2°	0	632X10-2°	■ ■		642X10-2°	■ ■	□ □
2°	0.08	-			642X10-2°-R08	■ ■	□ □
2°	0.15	-			642X10-2°-R15	■ ■	□ □

L

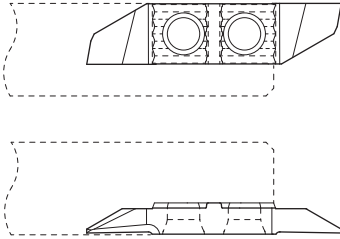

R

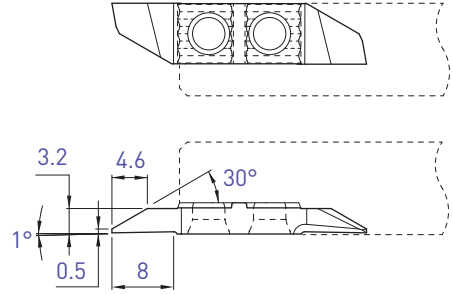

Tournage avant
Vorwärts drehen
Front turning

L				R			
Art. N°	TiAlN N (µk20)	HTA	HN (µk10)	Art. N°	TiAlN N (µk20)	HTA	HN (µk10)
632S05	■ ■			642S05	■ ■	□ □	

Tournage multifonction

Mehrweck drehen

Multifunction turning

633S / 643S

L

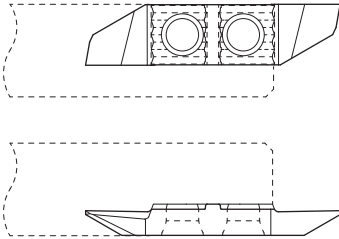

R

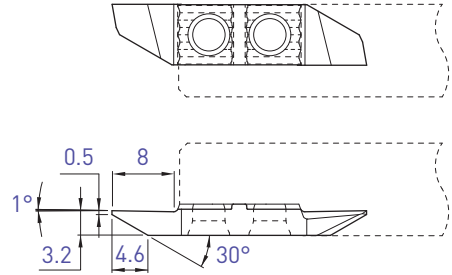

Tournage arrière
Rückwärts drehen
Back turning

L				R			
Art. N°	TiAlN N [µk20]	HTA	HN [µk10]	Art. N°	TiAlN N [µk20]	HTA	HN [µk10]
633S05	■ ■			643S05	■ ■	□ □	

L

R

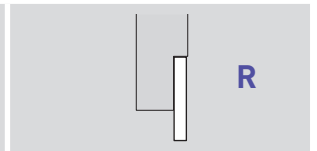
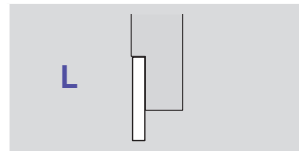
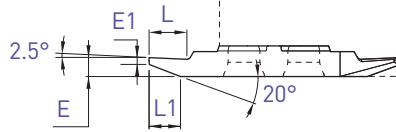
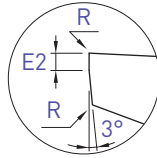
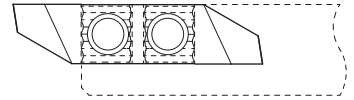
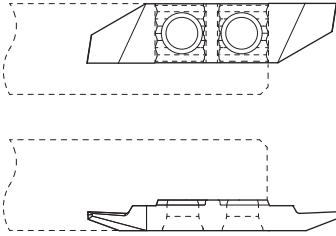

E1	E2	L	L1	E	R	Art. N°	TiAlN N (µk20)	HTA HN (µk10)	Art. N°	TiAlN N (µk20)	HTA HN (µk10)
0.5	0.25	3	2.8	1.5	0	633-0.5	■ ■		643-0.5	■ ■	□ □
0.5	0.25	3	2.8	1.5	0.08	-			643-0.5-R08	■ ■	□ □
0.8	0.40	4.5	3.3	2.0	0	-			643-0.8	■ ■	□ □
0.8	0.40	4.5	3.3	2.0	0.08	-			643-0.8-R08	■ ■	□ □
1.0	0.40	5	4.2	2.5	0	-			643-1.0	■ ■	□ □
1.0	0.40	5	4.2	2.5	0.08	-			643-1.0-R08	■ ■	□ □
1.5	0.50	6	4.2	3.0	0	-			643-1.5	■ ■	□ □
1.5	0.50	6	4.2	3.0	0.08	-			643-1.5-R08	■ ■	□ □

Tournage arrière
 Rückwärts drehen
 Back turning

633X / 643X

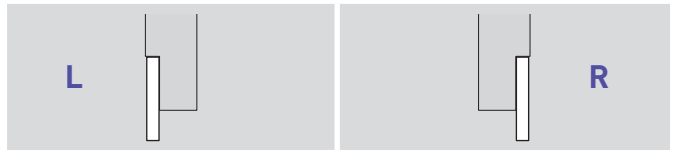
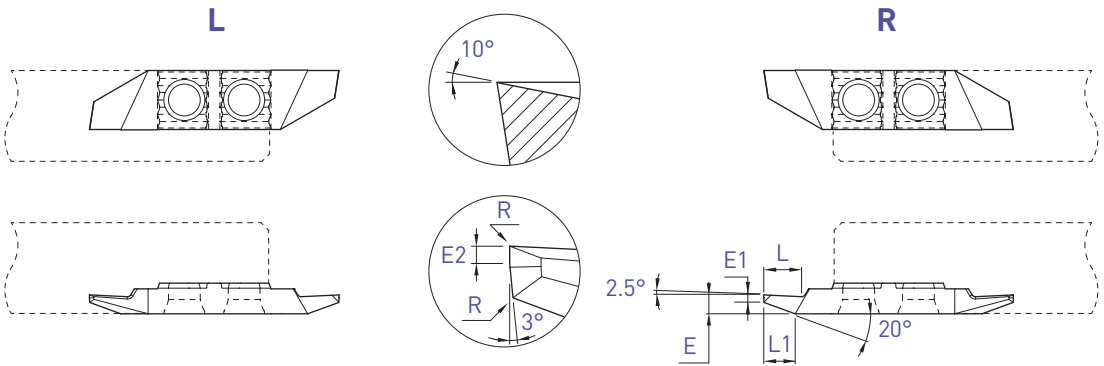

E1	E2	L	L1	E	R	Art. N°	TiAlN N (µk20)	HTA HN (µk10)	Art. N°	TiAlN N (µk20)	HTA HN (µk10)
0.5	0.25	3	2.8	1.5	0	633X10-0.5	■ ■		643X10-0.5	■ ■	□ □
0.5	0.25	3	2.8	1.5	0.08	-			643X10-0.5-R08	■ ■	□ □
0.8	0.40	4.5	3.3	2.0	0	-			643X10-0.8	■ ■	□ □
0.8	0.40	4.5	3.3	2.0	0.08	-			643X10-0.8-R08	■ ■	□ □
1.0	0.40	5	4.2	2.5	0	-			643X10-1.0	■ ■	□ □
1.0	0.40	5	4.2	2.5	0.08	-			643X10-1.0-R08	■ ■	□ □
1.5	0.50	6	4.2	3.0	0	-			643X10-1.5	■ ■	□ □
1.5	0.50	6	4.2	3.0	0.08	-			643X10-1.5-R08	■ ■	□ □

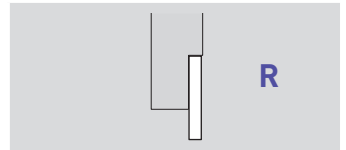
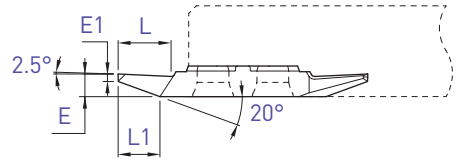
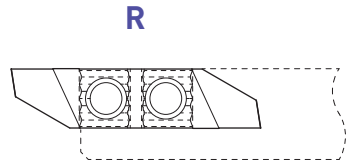
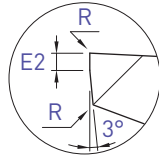
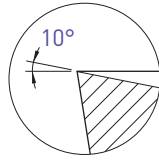

E1	E2	L	L1	E	R	Art. N°	TiAlN N [µk20]	HTA	HN [µk10]
1.0	0.4	7	5.5	3.0	0	643X10S-1.0	■ ■	□ □	
1.0	0.4	7	5.5	3.0	0.08	643X10S-1.0-R08	■ ■	□ □	

Tournage arrière
 Rückwärts drehen
 Back turning

643VX8

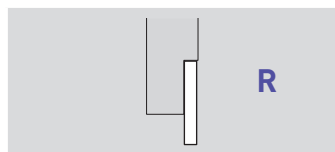
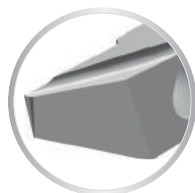
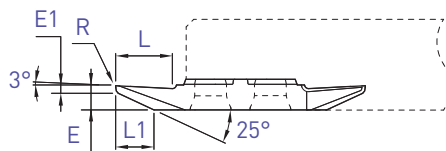
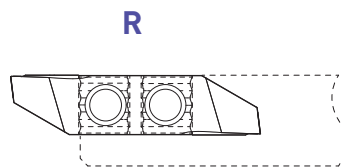
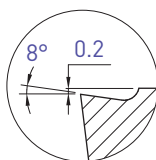

E1	L	L1	E	R	Art. N°	TiAlN N [µk20]	HTA	HN [µk10]
1.0	7.5	5.0	3.2	0	643VX8	■ ■	□ □	
1.0	7.5	5.0	3.2	0.08	643VX8-R08	■ ■	□ □	

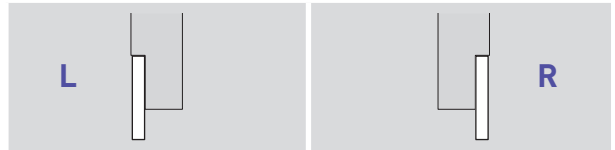
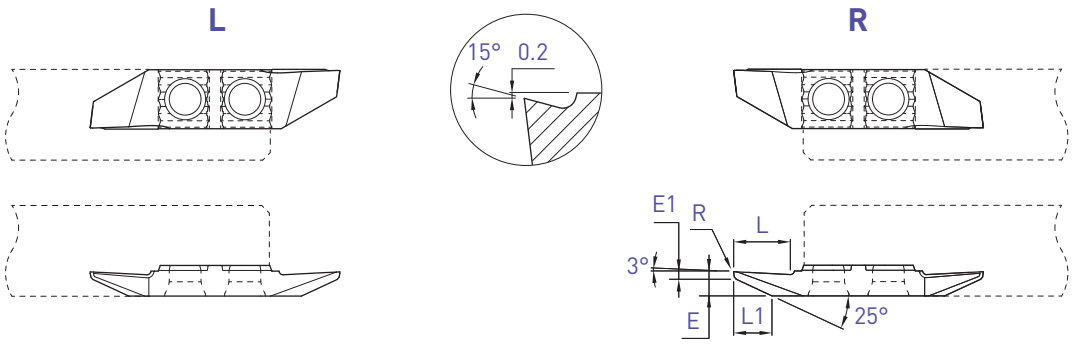

E1	L	L1	E	R	Art. N°	TiAlN N [µk20]	HTA HN [µk10]	Art. N°	TiAlN N [µk20]	HTA HN [µk10]
0.6	7.5	5.2	3.2	0	633VX15	■ ■		643VX15	■ ■	□ □
0.6	7.5	5.2	3.2	0.08	-			643VX15-R08	■ ■	□ □

Tournage arrière
 Rückwärts drehen
 Back turning

643VUX

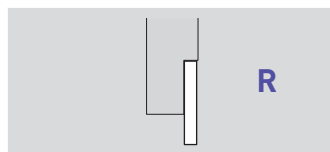
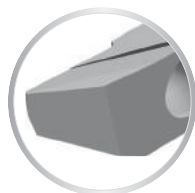
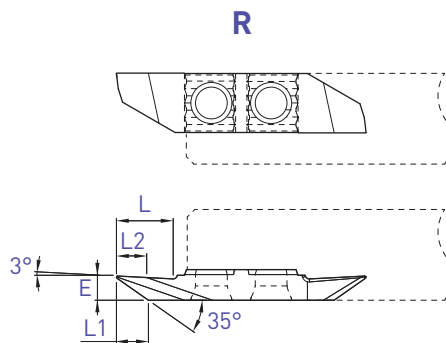
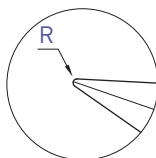
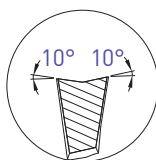

L	L1	L2	E	R	Art. N°	TiAlN N [µk20]	HTA	HN [µk10]
7.5	4.2	4.0	3.2	0.15	643VUX10-R15	■ ■	□ □	
7.5	3.8	3.8	3.2	0.35	643VUX10-R35	■ ■	□ □	

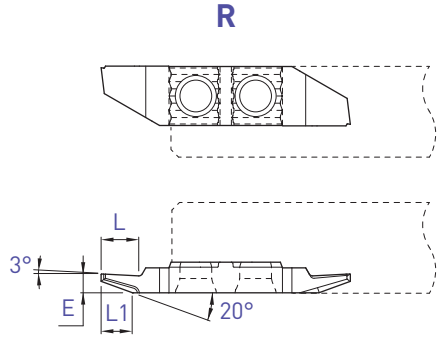
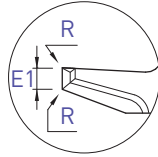
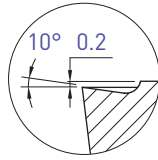

Pour un meilleur contrôle des copeaux
Für eine bessere Spankontrolle
For a better chip control

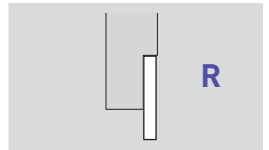

E1	L	L1	E	R	Art. N°	TiAlN N (µk20)
1.0	5	4	2.5	0.01	643ZX10-1.0	■
1.0	5	4	2.5	0.08	643ZX10-1.0-R08	■

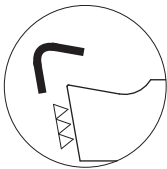

Arête de coupe honée
Gehonte Schneidkante
Honed edge

f min: 0.02 mm/U

Fonçage-tournage

Einstecken und drehen

Grooving and turning

634 / 644

L

R

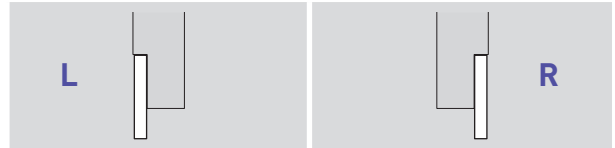
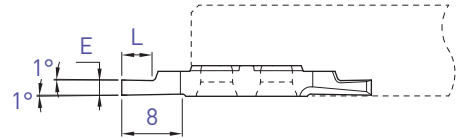
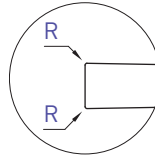
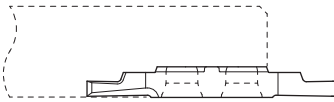
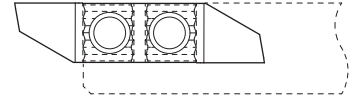
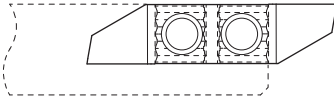

E	L	R	Art. N°	TiAlN N (µk20)	HTA HN (µk10)	Art. N°	TiAlN N (µk20)	HTA HN (µk10)
0.5	1.5	0	634-0.5	■ ■		644-0.5	■ ■	□ □
0.6	1.8	0	-			644-0.6	■ ■	□ □
0.75	2	0	-			644-0.75	■ ■	□ □
0.8	2	0	634-0.8	■ ■		644-0.8	■ ■	□ □
0.9	2.5	0	-			644-0.9	■ ■	□ □
0.95	3	0	-			644-0.95	■ ■	□ □
1.0	2.5	0	634-1.0	■ ■		644-1.0	■ ■	□ □
1.0	2.5	0.08	-			644-1.0-R08	■ ■	□ □
1.2	3	0	634-1.2	■ ■		644-1.2	■ ■	□ □
1.2	3	0.08	-			644-1.2-R08	■ ■	□ □
1.5	3	0	634-1.5	■ ■		644-1.5	■ ■	□ □
1.5	3	0.08	-			644-1.5-R08	■ ■	□ □
1.5	3	0.15	-			644-1.5-R15	■ ■	□ □
1.8	4	0	-			644-1.8	■ ■	□ □
2.0	4	0	634-2.0	■ ■		644-2.0	■ ■	□ □
2.0	4	0.08	-			644-2.0-R08	■ ■	□ □
2.0	4	0.15	-			644-2.0-R15	■ ■	□ □
2.5	6	0	634-2.5	■ ■		644-2.5	■ ■	□ □
2.5	6	0.08	-			644-2.5-R08	■ ■	□ □
2.5	6	0.15	-			644-2.5-R15	■ ■	□ □
3	6	0	634-3.0	■ ■		644-3.0	■ ■	□ □
3	6	0.08	-			644-3.0-R08	■ ■	□ □
3	6	0.15	-			644-3.0-R15	■ ■	□ □

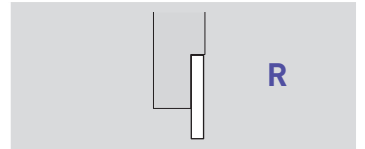
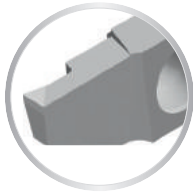
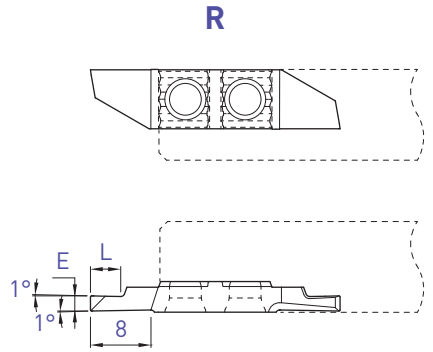
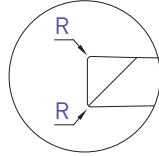
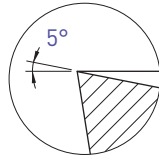

E	L	R	Art. N°	TiAlN N (µk20)	HTA	HN (µk10)
1.5	3	0.08	644X5-1.5-R08	■ ■	□ □	
2	4	0.08	644X5-2.0-R08	■ ■	□ □	
2	4	0.15	644X5-2.0-R15	■ ■	□ □	
2.5	6	0.08	644X5-2.5-R08	■ ■	□ □	
2.5	6	0.15	644X5-2.5-R15	■ ■	□ □	
3	6	0.08	644X5-3.0-R08	■ ■	□ □	
3	6	0.15	644X5-3.0-R15	■ ■	□ □	

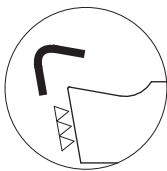
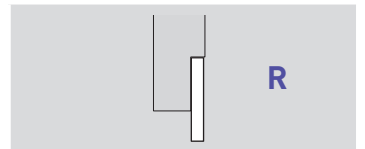

Arête de coupe honée
 Gehonte Schneidkante
 Honed edge

f min: 0.02 mm/U

E	L	R	Art. N°	TiAlN N (µk20)	HTA	HN (µk10)
1.5	3	0.08	644X5-1.5-R08-EP	■ ■		
2	4	0.08	644X5-2.0-R08-EP	■ ■		
2	4	0.15	644X5-2.0-R15-EP	■ ■		
2.5	6	0.08	644X5-2.5-R08-EP	■ ■		
2.5	6	0.15	644X5-2.5-R15-EP	■ ■		
3	6	0.08	644X5-3.0-R08-EP	■ ■		
3	6	0.15	644X5-3.0-R15-EP	■ ■		

Fonçage-tournage

Einstecken und drehen

Grooving and turning

634X10 / 644X10

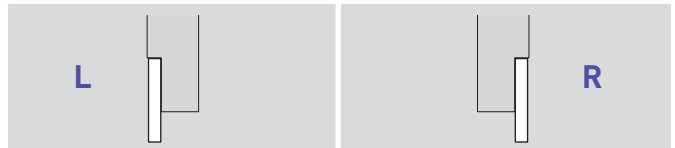
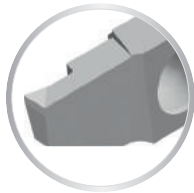
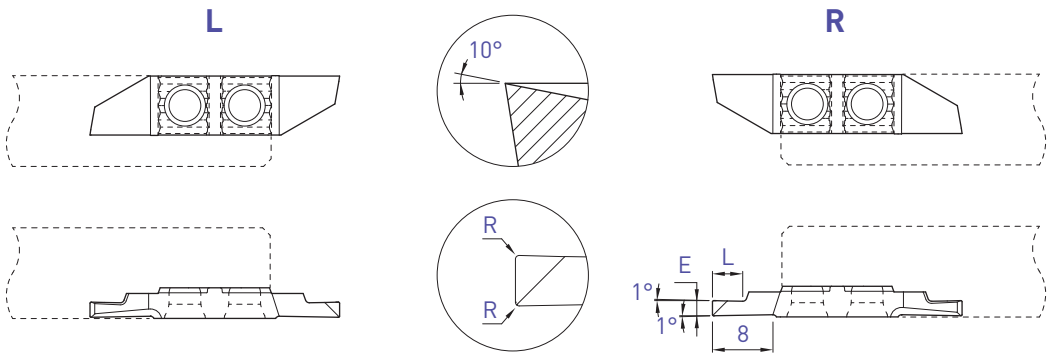

			L				R			
E	L	R	Art. N°	TiAlN N (µk20)	HTA HN (µk10)	Art. N°	TiAlN N (µk20)	HTA HN (µk10)		
0.8	2	0	634X10-0.8	■ ■		644X10-0.8	■ ■	□ □		
1.0	2.5	0	634X10-1.0	■ ■		644X10-1.0	■ ■	□ □		
1.0	2.5	0.08	634X10-1.0-R08	■ ■		644X10-1.0-R08	■ ■	□ □		
1.2	3	0	-			644X10-1.2	■ ■	□ □		
1.2	3	0.08	-			644X10-1.2-R08	■ ■	□ □		
1.5	3	0	634X10-1.5	■ ■		644X10-1.5	■ ■	□ □		
1.5	3	0.08	634X10-1.5-R08	■ ■		644X10-1.5-R08	■ ■	□ □		
1.5	3	0.15	634X10-1.5-R15	■ ■		644X10-1.5-R15	■ ■	□ □		
1.8	4	0	-			644X10-1.8	■ ■	□ □		
2	4	0	634X10-2.0	■ ■		644X10-2.0	■ ■	□ □		
2	4	0.08	634X10-2.0-R08	■ ■		644X10-2.0-R08	■ ■	□ □		
2	4	0.15	634X10-2.0-R15	■ ■		644X10-2.0-R15	■ ■	□ □		
2.5	6	0	634X10-2.5	■ ■		644X10-2.5	■ ■	□ □		
2.5	6	0.08	634X10-2.5-R08	■ ■		644X10-2.5-R08	■ ■	□ □		
2.5	6	0.15	634X10-2.5-R15	■ ■		644X10-2.5-R15	■ ■	□ □		
3	6	0	634X10-3.0	■ ■		644X10-3.0	■ ■	□ □		
3	6	0.08	634X10-3.0-R08	■ ■		644X10-3.0-R08	■ ■	□ □		
3	6	0.15	634X10-3.0-R15	■ ■		644X10-3.0-R15	■ ■	□ □		

■ = disponible / verfügbar / available
 □ = selon disponibilité du stock / jenach Lagerverfügbarkeit / depending on stock availability

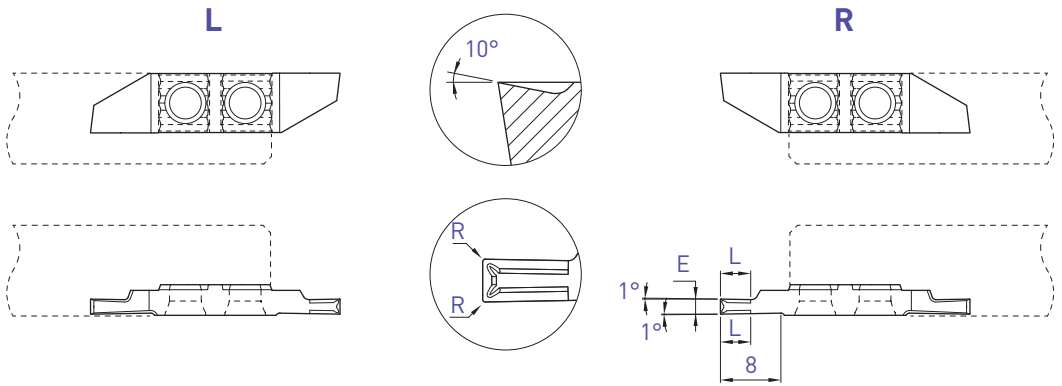

Pour un meilleur contrôle des copeaux
Für eine bessere Spankontrolle
For a better chip-control

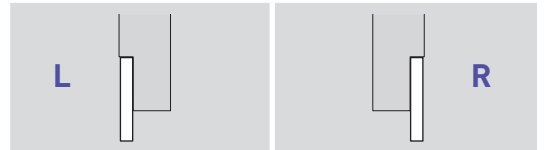

E	L	R	Art. N°	TiAlN N (µk20)	Art. N°	TiAlN N (µk20)
1.0	2.5	0.01	634ZXB10-1.0	■	644ZXB10-1.0	■
1.5	4	0.01	634ZXB10-1.5	■	644ZXB10-1.5	■
1.5	4	0.08	634ZXB10-1.5-R08	■	644ZXB10-1.5-R08	■
2.0	4	0.01	634ZXB10-2.0	■	644ZXB10-2.0	■
2.0	4	0.08	634ZXB10-2.0-R08	■	644ZXB10-2.0-R08	■
2.0	4	0.15	634ZXB10-2.0-R15	■	644ZXB10-2.0-R15	■
2.5	5	0.08	634ZXB10-2.5-R08	■	644ZXB10-2.5-R08	■
2.5	5	0.15	634ZXB10-2.5-R15	■	644ZXB10-2.5-R15	■
3.0	6	0.08	634ZXB10-3.0-R08	■	644ZXB10-3.0-R08	■
3.0	6	0.15	634ZXB10-3.0-R15	■	644ZXB10-3.0-R15	■
3.0	6	0.35	634ZXB10-3.0-R35	■	644ZXB10-3.0-R35	■

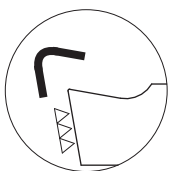

Arête de coupe honée
Gehonte Schneidkante
Honed edge

f min: 0.02 mm/U

Fonçage-tournage

Einstecken und drehen

Grooving and turning

634ZXT / 644ZXT

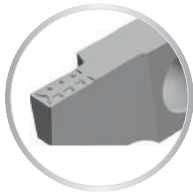
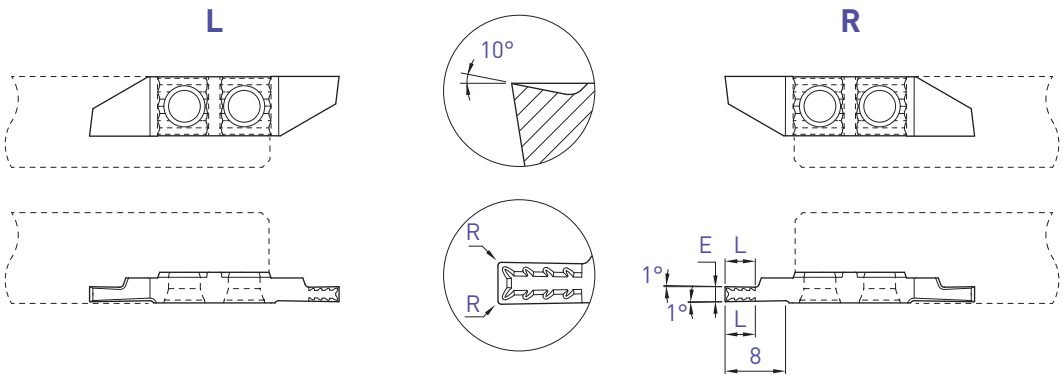

Pour un meilleur contrôle des copeaux
Für eine bessere Spankontrolle
For a better chip-control

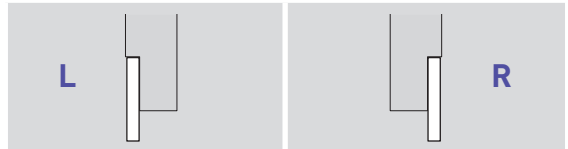

E	L	R	Art. N°	TiAlN N (µm20)	Art. N°	TiAlN N (µm20)
1.0	2.5	0.01	634ZXT10-1.0	■	644ZXT10-1.0	■
1.5	4	0.01	634ZXT10-1.5	■	644ZXT10-1.5	■
1.5	4	0.08	634ZXT10-1.5-R08	■	644ZXT10-1.5-R08	■
2.0	4	0.01	634ZXT10-2.0	■	644ZXT10-2.0	■
2.0	4	0.08	634ZXT10-2.0-R08	■	644ZXT10-2.0-R08	■
2.0	4	0.15	634ZXT10-2.0-R15	■	644ZXT10-2.0-R15	■
2.5	5	0.08	634ZXT10-2.5-R08	■	644ZXT10-2.5-R08	■
2.5	5	0.15	634ZXT10-2.5-R15	■	644ZXT10-2.5-R15	■
3.0	6	0.08	634ZXT10-3.0-R08	■	644ZXT10-3.0-R08	■
3.0	6	0.15	634ZXT10-3.0-R15	■	644ZXT10-3.0-R15	■
3.0	6	0.35	-		644ZXT10-3.0-R35	■

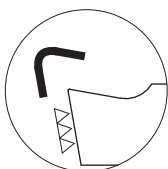

Arête de coupe honée
Gehonte Schneidkante
Honed edge

f min: 0.02 mm/U

Chanfreinage

Anfasen

Chamfering

635-90 / 645-90

L

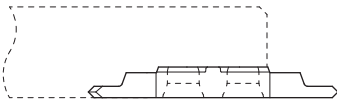
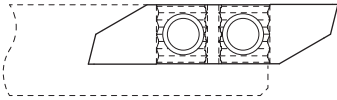

R

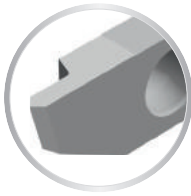
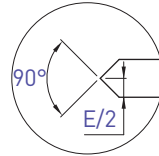
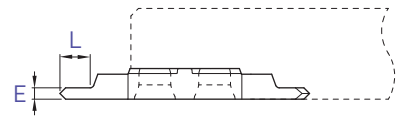
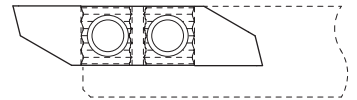

L

R

E	L	Art. N°	TiAlN N (µk20)	Art. N°	TiAlN N (µk20)
1.5	4	635-90-1.5	■ ■	645-90-1.5	■ ■

Chanfreinage

Anfasen

Chamfering

635X-90 / 645X-90

L

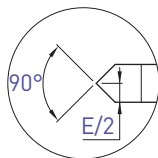
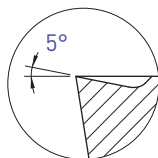
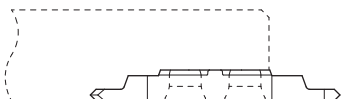
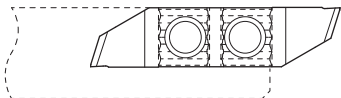

R

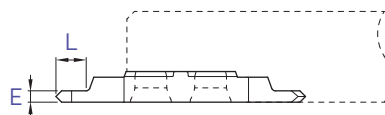
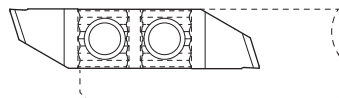

L



R



E	L	Art. N°	TiAlN N (µk<20)	Art. N°	TiAlN N (µk<20)
1.5	4	635X5-90-1.5	■ ■	645X5-90-1.5	■ ■

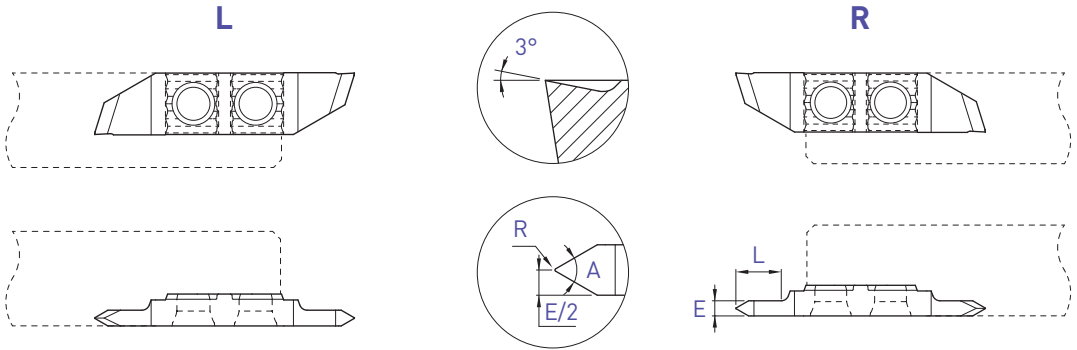

Profil partiel
Teilprofil
Partial profile

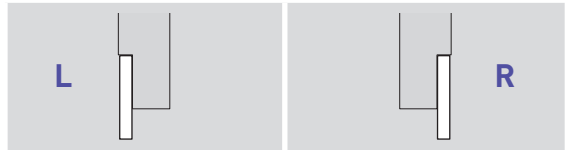

A	E	L	R	Art. N°	TiAlN N (µk20)	Art. N°	TiAlN N (µk20)
55°	1.5	4	0	636X3-55-1.5	■ ■	646X3-55-1.5	■ ■
55°	2.0	6	0.03	636X3-55-2.0-R03	■ ■	646X3-55-2.0-R03	■ ■
60°	1.5	4	0	636X3-60-1.5	■ ■	646X3-60-1.5	■ ■
60°	2.0	6	0.03	636X3-60-2.0-R03	■ ■	646X3-60-2.0-R03	■ ■
60°	2.0	6	0.06	636X3-60-2.0-R06	■ ■	646X3-60-2.0-R06	■ ■
60°	3.0	8	0.06	636X3-60-3.0-R06	■ ■	646X3-60-3.0-R06	■ ■
60°	3.0	8	0.12	636X3-60-3.0-R12	■ ■	646X3-60-3.0-R12	■ ■

Filetage

Gewinde drehen

Threading

636X-M / 646X-M

L

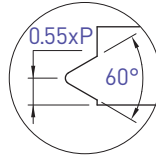
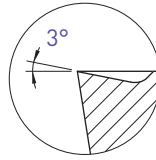
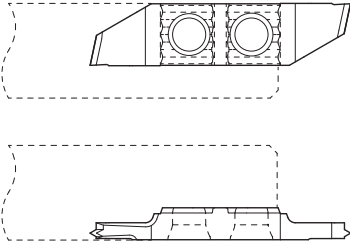

R

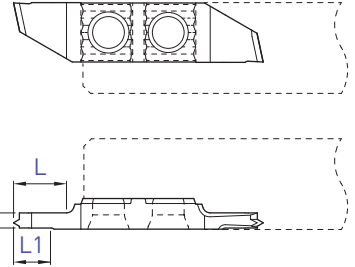

Profil complet métrique
Metrisches Vollprofil
Metric full profile

L



R



E	L	L1	Pas Steigung Pitch P	Art. N°	TiAlN N (µk20)	Art. N°	TiAlN N (µk20)
1.0	3	3	0.25	636X3-M-0.25	■ ■	646X3-M-0.25	■ ■
1.0	3	3	0.30	636X3-M-0.30	■ ■	646X3-M-0.30	■ ■
1.0	3	3	0.35	636X3-M-0.35	■ ■	646X3-M-0.35	■ ■
1.0	3	3	0.40	636X3-M-0.40	■ ■	646X3-M-0.40	■ ■
1.0	3	3	0.45	636X3-M-0.45	■ ■	646X3-M-0.45	■ ■
1.0	3	3	0.50	636X3-M-0.50	■ ■	646X3-M-0.50	■ ■
1.5	5	5	0.60	636X3-M-0.60	■ ■	646X3-M-0.60	■ ■
1.5	5	5	0.70	636X3-M-0.70	■ ■	646X3-M-0.70	■ ■
1.5	5	5	0.75	636X3-M-0.75	■ ■	646X3-M-0.75	■ ■
1.5	5	5	0.80	636X3-M-0.80	■ ■	646X3-M-0.80	■ ■
2.0	7	5	1.00	636X3-M-1.00	■ ■	646X3-M-1.00	■ ■
2.0	7	5	1.25	636X3-M-1.25	■ ■	646X3-M-1.25	■ ■
2.0	7	5	1.50	636X3-M-1.50	■ ■	646X3-M-1.50	■ ■

PRO-LINE

Plaquettes à rayon
 Radius Wendeplatten
 Radius inserts

637 / 647

L

R

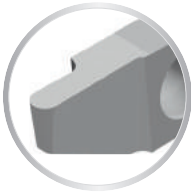
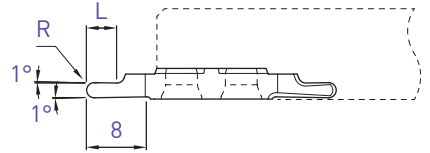
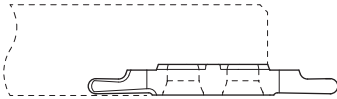
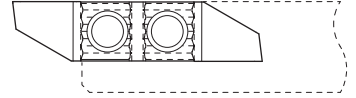
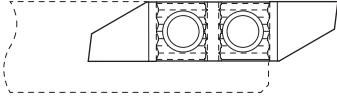

L

R

R	L	Art. N°	TiAlN N (µk20)	HTA HN (µk10)	Art. N°	TiAlN N (µk20)	HTA HN (µk10)
0.25	1.5	-			647-R0.25	■ ■	
0.4	2	-			647-R0.4	■ ■	
0.5	2.5	637-R0.5	■ ■		647-R0.5	■ ■ □ □	
0.6	2.5	-			647-R0.6	■ ■	
0.75	3	-			647-R0.75	■ ■	
0.8	3	-			647-R0.8	■ ■	
1.0	4	637-R1.0	■ ■		647-R1.0	■ ■	
1.5	6	-			647-R1.5	■ ■	

Plaquettes à rayon
 Radius Wendplatten
 Radius inserts

647ZX10

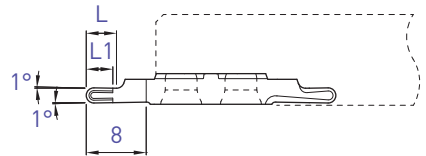
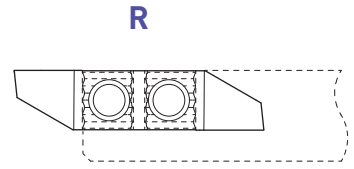
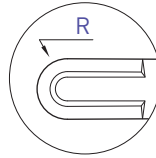
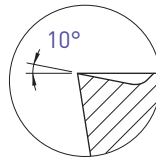

Pour un meilleur contrôle des copeaux
 Für eine bessere Spankontrolle
 For a better chip-control

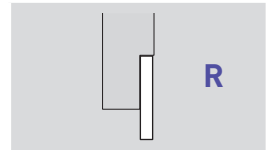

R	L	L1	Art. N°	TiAlN N (µk20)
1.0	4	3.5	647ZX10-R1.0	■
1.5	6	4	647ZX10-R1.5	■

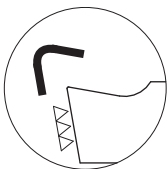

Arête de coupe honée
 Gehonte Schneidkante
 Honed edge

f min: 0.02 mm/U

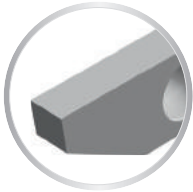
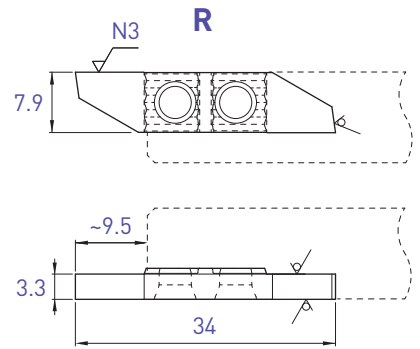
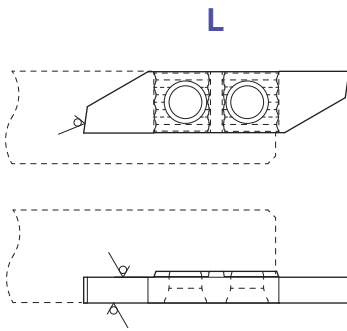

Face de coupe polie
 Polierte Schneidfläche
 Polished cutting face

L			R		
Art. N°	TiAlN N (µk20)	HTA HN (µk10)	Art. N°	TiAlN N (µk20)	HTA HN (µk10)
631-EP	■ ■	■ ■	641-EP	■ ■	■ ■

Porte-outils

Halter

Holder

650 / 660

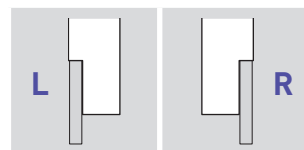
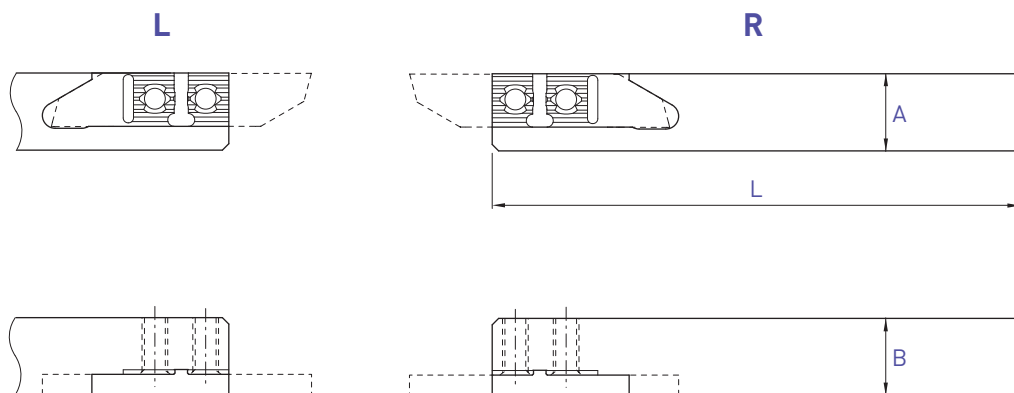

A x B	L	Art. N°	Art. N°
8 x 8	115	650-8	660-8
10 x 10	115	650-10	660-10
10 x 10	50	650-10-50	660-10-50
12 x 12	130	650-12	660-12
12 x 12	90	650-12-90	660-12-90
12.7 x 12.7	130	650-12.7	660-12.7
16 x 16	130	650-16	660-16
16 x 16	75	650-16-75	660-16-75
20 x 20	120	650-20	660-20

Chaque support est livré avec vis et clé.

Jeder Halter wird mit Spannschraube(n) und Schlüssel geliefert.

Screw(s) and key are included with each tool holder.

■ = disponible / verfügbar / available

□ = selon disponibilité du stock / jenach Lagerverfügbarkeit / depending on stock availability

Porte-outils

Halter

Holder

Coupe à droite déportée

Versetztes Rechtsschneiden

Right cut off line

650 RC

Utiliser des plaquettes type 651R
WSP Typ 651R verwenden
Use inserts type 651R

Voir dès page 3.39
Siehe ab Seite 3.39
See from page 3.39

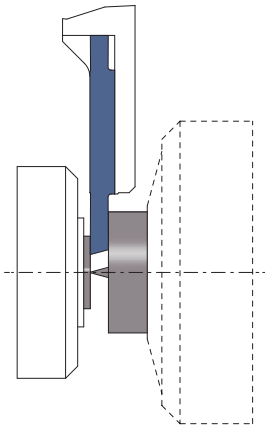
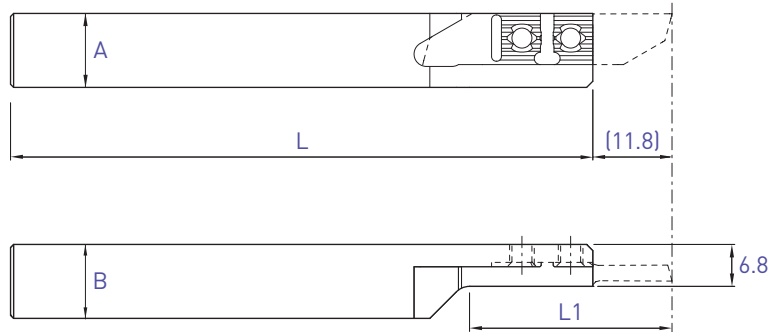

L (R)			
Coupe à droite déportée Versetztes Rechtsschneiden Right cut off line			
A x B	L	L1	Art. N°
10 x 10	115	32	650RC-10
12 x 12	130	32	650RC-12
16 x 16	130	42	650RC-16

Chaque support est livré avec vis et clé.
Jeder Halter wird mit Spannschraube(n) und Schlüssel geliefert.
Screw(s) and key are included with each tool holder.

Porte-outils avec arrosage intégré
 Halter mit integrierter Kühlmittelzufuhr
 Holders with integrated coolant supply

650-JET / 660-JET

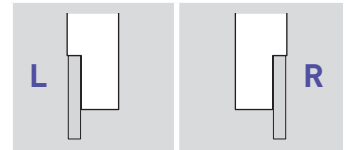
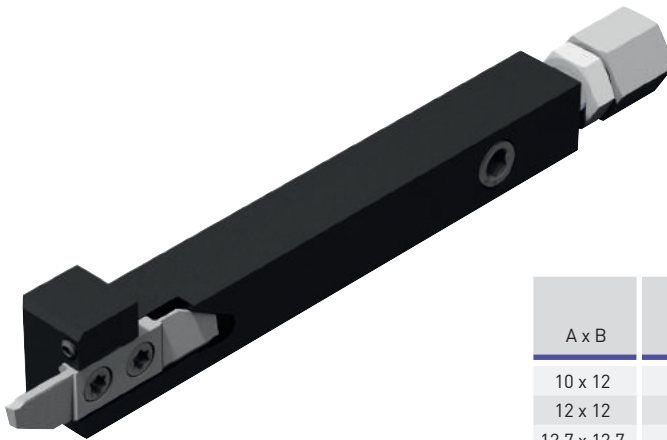
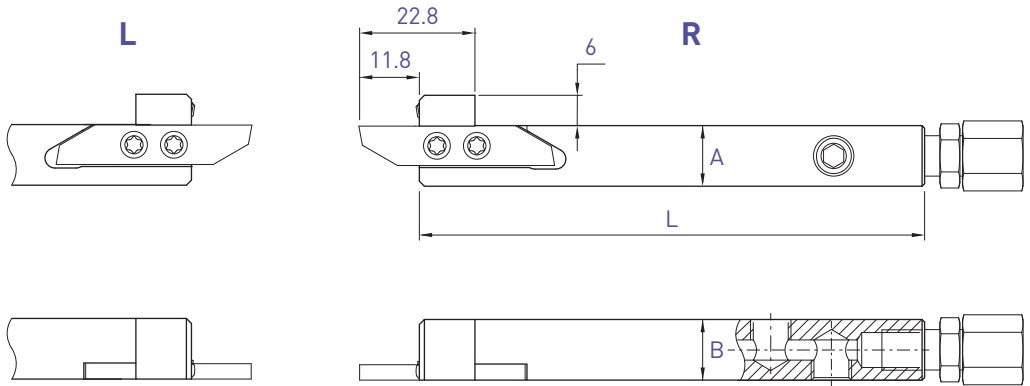

A x B	L	Art. N°	Art. N°
10 x 12	100	650-1012-JET	660-1012-JET
12 x 12	100	650-12-JET	660-12-JET
12.7 x 12.7	100	650-12.7-JET	660-12.7-JET
16 x 16	100	650-16-JET	660-16-JET
20 x 20	100	650-20-JET	660-20-JET

Chaque support est livré avec vis, clé, raccord droit et buse d'arrosage Ø 1.5 mm.
 Jeder Halter wird mit Spannschraube(n), Schlüssel, gerader Kühlmittelanschluss und Kühlmitteldüse Ø 1.5 mm geliefert.
 Screws(s), key, straight connector and coolant nozzle Ø 1.5 mm are included with each tool holder.

L

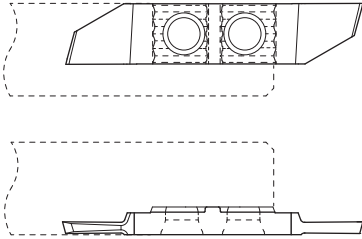

R

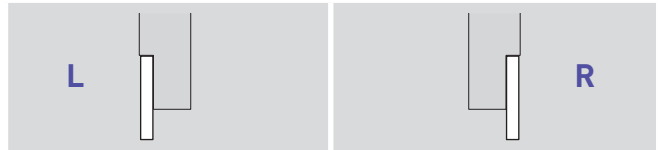
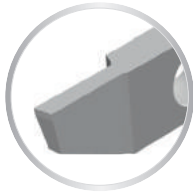
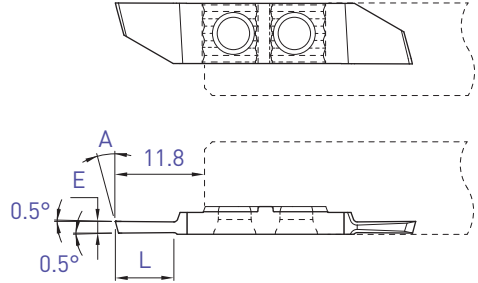

E	A	L	L				R			
			Art. N°	TiAlN N [µk20]	HTA HN [µk10]	Art. N°	TiAlN N [µk20]	HTA HN [µk10]		
0.8	20°	5	651-0.8-20°	■ ■		661-0.8-20°	■ ■	□ □		
1.0	15°	5	-			661-1.0-15°	■ ■	□ □		
1.0	20°	5	651-1.0-20°	■ ■		661-1.0-20°	■ ■	□ □		
1.2	15°	5	-			661-1.2-15°	■ ■	□ □		
1.2	20°	5	651-1.2-20°	■ ■		661-1.2-20°	■ ■	□ □		
1.5	15°	7.5	651-1.5-15°	■ ■		661-1.5-15°	■ ■	□ □		
1.5	20°	7.5	-			661-1.5-20°	■ ■	□ □		
1.8	15°	9	651-1.8-15°	■ ■		661-1.8-15°	■ ■	□ □		
2.0	15°	11	651-2.0-15°	■ ■		661-2.0-15°	■ ■	□ □		
2.5	15°	11	651-2.5-15°	■ ■		661-2.5-15°	■ ■	□ □		

Tronçonnage

Abstechen

Parting off

651XF / 661XF

L

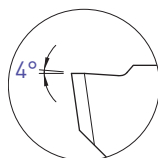
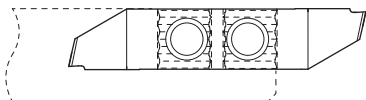

R

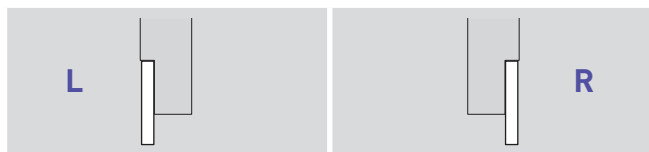
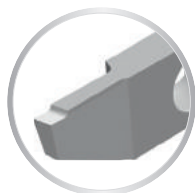
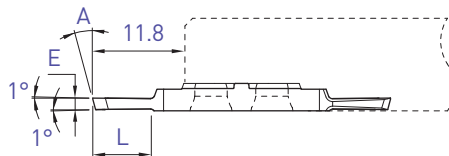
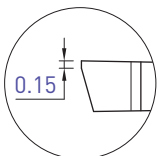
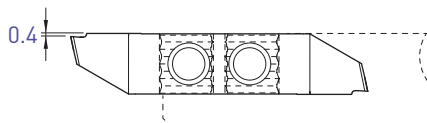

E	A	L	Art. N°	TiAlN N [µk20]	HTA HN [µk10]	Art. N°	TiAlN N [µk20]	HTA HN [µk10]
1.5	15°	7.5	651XF-1.5	■ ■		661XF-1.5	■ ■	□ □
2.0	15°	11	651XF-2.0	■ ■		661XF-2.0	■ ■	□ □

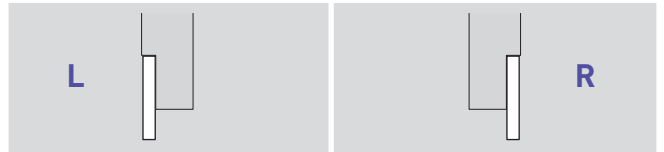
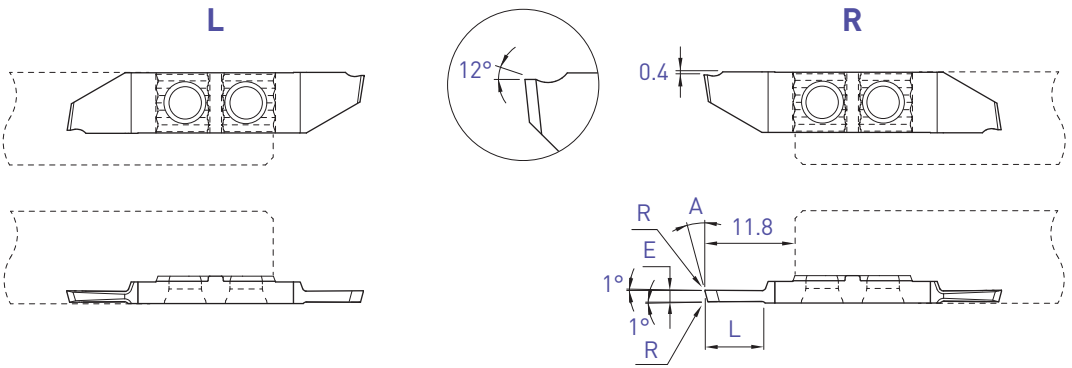

E	A	L	R	Art. N°	TiAlN N [µk20]	HTA HN [µk10]	Art. N°	TiAlN N [µk20]	HTA HN [µk10]
1.0	15°	5	0.03	651X12-1.0	■ ■		661X12-1.0	■ ■	□ □
1.5	15°	7.5	0.03	651X12-1.5	■ ■		661X12-1.5	■ ■	□ □
2.0	15°	11	0.03	651X12-2.0	■ ■		661X12-2.0	■ ■	□ □

Tronçonnage

Abstechen

Parting off

651U / 661U

L

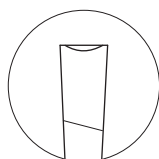
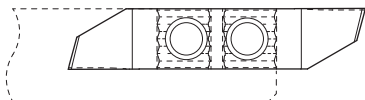

R

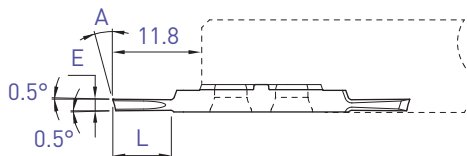
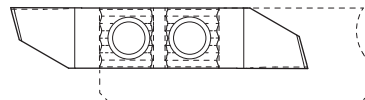

L

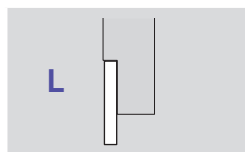

R

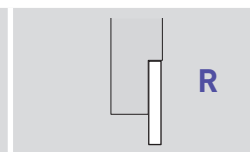

E	A	L	Art. N°	TiAlN N (µm20)	Art. N°	TiAlN N (µm20)
1.5	15°	7.5	651U-1.5	■ ■	661U-1.5	■ ■
2.0	15°	11	651U-2.0	■ ■	661U-2.0	■ ■

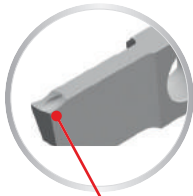
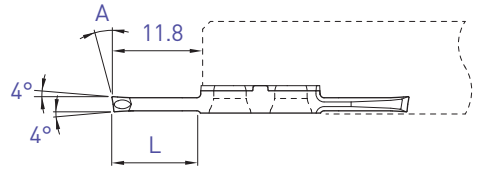
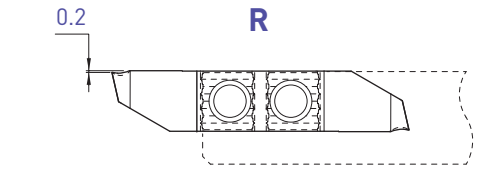
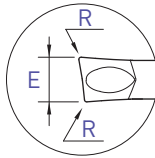
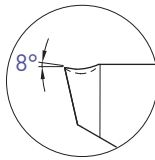

Pour un meilleur contrôle des copeaux
Für eine bessere Spankontrolle
For a better chip-control

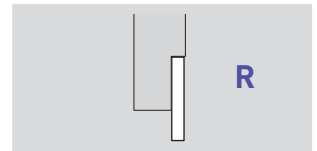
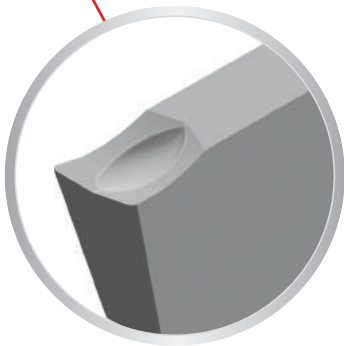

E	A	L	R	Art. N°	TiAlN N (µk20)
2.0	8°	11	0.10	661ZU8-2.0-8°-R10	■

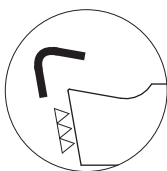

Arête de coupe honée
Gehonte Schneidkante
Honed edge

f min: 0.02 mm/U

Tronçonnage
Abstechen
Parting off

Coupe déportée
Versetztes Schneiden
Cut off line

651R

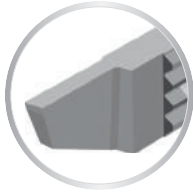

Cut R

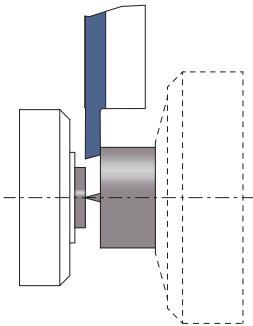
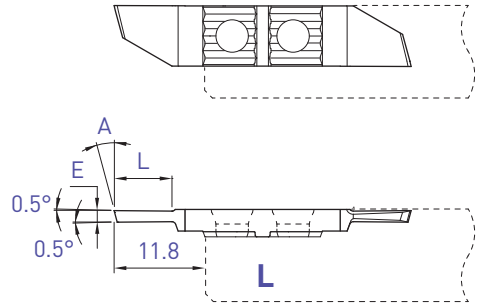

L (R)

Coupe à droite déportée
Versetztes Rechtsschneiden
Right cut off line

E	A	L	Art. N°	Ti/AlN N (µk20)	HTA	HN (µk10)
1.0	15°	5	651R-1.0-15°	■ ■	□ □	
1.2	15°	5	651R-1.2-15°	■ ■	□ □	
1.5	15°	7.5	651R-1.5-15°	■ ■	□ □	
2.0	15°	11	651R-2.0-15°	■ ■	□ □	
2.5	15°	11	651R-2.5-15°	■ ■	□ □	

Tronçonnage
 Abstechen
 Parting off

Coupe déportée
 Versetztes Schneiden
 Cut off line

651RXF

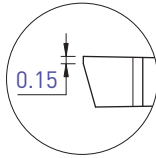
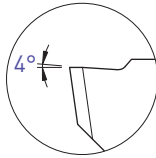
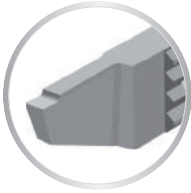

Cut R

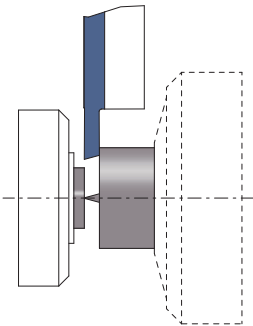
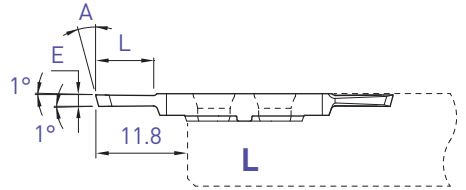
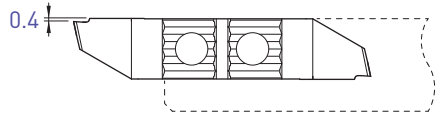

L (R)

Coupe à droite déportée
 Versetztes Rechtsschneiden
 Right cut off line

E	A	L	Art. N°	Ti/AIN N (µk20)	HTA	HN (µk10)
1.5	15°	7.5	651RXF-1.5	■ ■	□ □	
2.0	15°	11	651RXF-2.0	■ ■	□ □	

Tronçonnage
Abstechen
Parting off

Coupe déportée
Versetztes Schneiden
Cut off line

651RX12

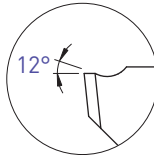
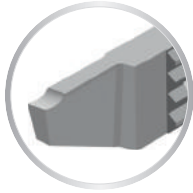

Cut R

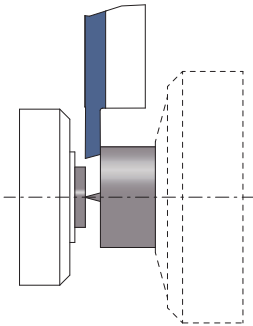
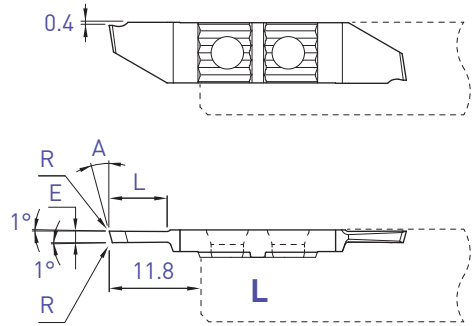

L (R)

Coupe à droite déportée
Versetztes Rechtsschneiden
Right cut off line

E	A	L	R	Art. N°	Ti/AIN N (µk20)	HTA	HN (µk10)
1.5	15°	7.5	0.03	651RX12-1.5	■ ■	□ □	
2.0	15°	11	0.03	651RX12-2.0	■ ■	□ □	

Tronçonnage
 Abstechen
 Parting off

Coupe déportée
 Versetztes Schneiden
 Cut off line

651RU

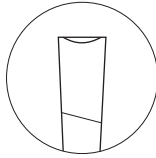

Cut R

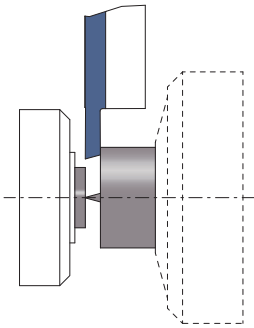
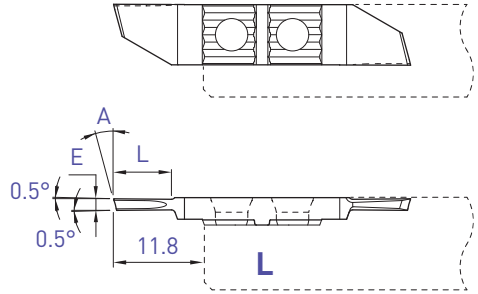

L (R)

Coupe à droite déportée
 Versetztes Rechtsschneiden
 Right cut off line

E	A	L	Art. N°	TiAlN N (µk20)
1.5	15°	7.5	651RU-1.5	■ ■
2.0	15°	11	651RU-2.0	■ ■

Tronçonnage
Abstechen
Parting off

Coupe déportée
Versetztes Schneiden
Cut off line

651RZU

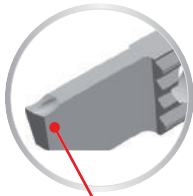
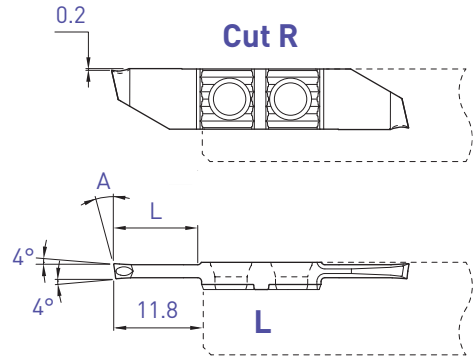
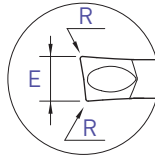
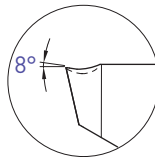

Pour un meilleur contrôle des copeaux
Für eine bessere Spankontrolle
For a better chip control

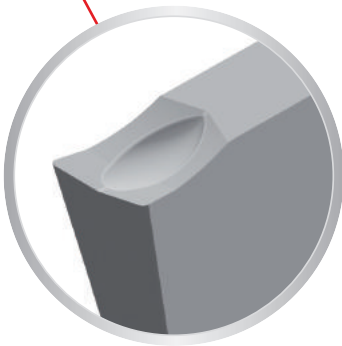

L (R)

Coupe à droite déportée
Versetztes Rechtsschneiden
Right cut off line

E	A	L	R	Art. N°	TiAlN N (µm20)
2.0	8°	11	0.10	651RZU8-2.0-8°-R10	■

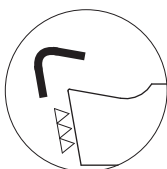

Arête de coupe honée
Gehonte Schneidkante
Honed edge

f min: 0.02 mm/U

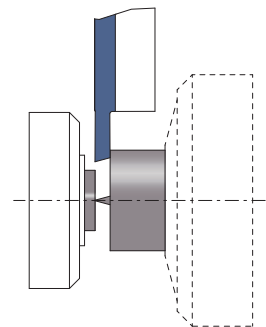

L

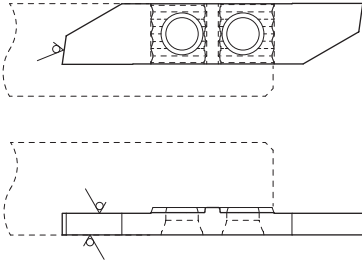

R

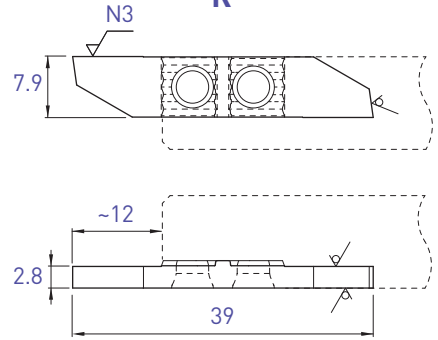





Face de coupe polie
 Polierte Schneidfläche
 Polished cutting face

L				R			
Art. N°	TiAlN N (µk20)	HTA	HN (µk10)	Art. N°	TiAlN N (µk20)	HTA	HN (µk10)
651-EP	■ ■	■ ■		661-EP	■ ■	■ ■	

Pièces de rechange et accessoires

Ersatzteile und Zubehöre

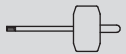
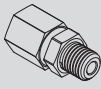
Spare parts and accessories

Pièces de rechange Ersatzteile Spare parts							
Porte-outils Halter Holders						Option Art. N°	Recommandation de serrage Drehmoment Empfehlung Clamping recommendation
630 640			-	-	-		
630-JET 640-JET	V-M4X9-T15		J-M8X1-D6	JB-M8X1	JJ-M3X6-D1.5		
650 660		C-T15	-	-	-	SET-NM-TX15	3 Nm
650-RC	V-M4X6.5-T15		-	-	-		
650-JET 660-JET	V-M4X9-T15		J-M8X1-D6	JB-M8X1	JJ-M3X6-D1.5		

■ = disponible / verfügbar / available

□ = selon disponibilité du stock / jenach Lagerverfügbarkeit / depending on stock availability