

A x B	L	R	Serrage Spansystem Clamping	Art. N°
8 x 8	115	24	A	740-C-8
10 x 10	115	24	A	740-C-10
12 x 12	130	30	A	740-C-12
16 x 16	130	40	A	740-C-16

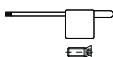

Chaque support est livré avec vis et clé.
Jeder Halter wird mit Spanschraube(n) und Schlüssel geliefert.
Screw(s) and key are included with each tool holder.

Porte-outils

Halter

Holders

Coupe à droite déportée

Versetztes Rechtsschneiden

Right cut off line

730RC

Utiliser des plaquettes type 731R
WSP Typ 731R verwenden
Use inserts type 731R

Voir pages 1.39 - 1.45
Siehe Seiten 1.39 - 1.45
See pages 1.39 - 1.45

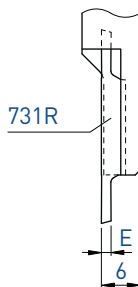
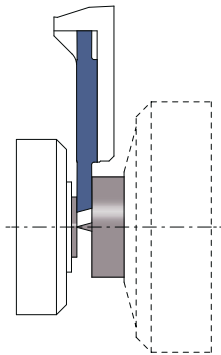
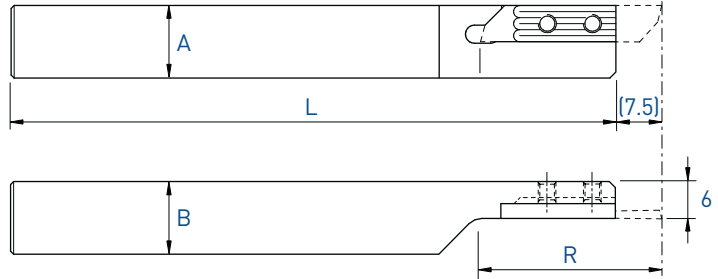

L (R)

Coupe à droite déportée
Versetztes Rechtsschneiden
Right cut off line

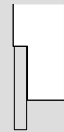

A x B	L	R	Art. N°
8 x 8	115	24	730RC-8
10 x 10	115	24	730RC-10
12 x 12	130	30	730RC-12
16 x 16	130	40	730RC-16



Chaque support est livré avec vis et clé.
Jeder Halter wird mit Spannschraube(n) und Schlüssel geliefert.
Screw(s) and key are included with each tool holder.

Porte-outils en métal lourd anti-vibratoire
 Schwingungsdämpfende Schwermetallhalter
 Low vibration heavy metal holders

730-NOVIBRA
740-NOVIBRA

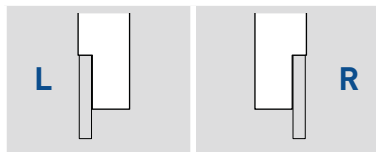
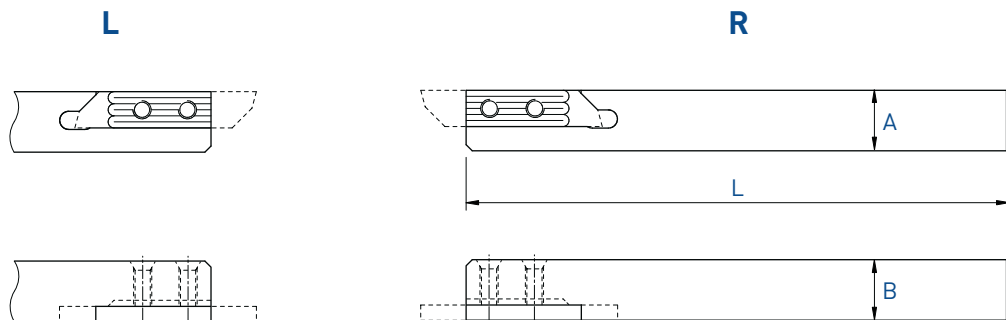

A x B	L	Serrage Spannsystem Clamping	Art. N°	Art. N°
7 x 7	115	A	730-7-NOVIBRA	740-7-NOVIBRA
8 x 8	115	A + B	730-8-NOVIBRA	740-8-NOVIBRA
8 x 8	80	A + B	-	740-8-80-NOVIBRA
10 x 10	115	A + B	-	740-10-NOVIBRA
12 x 12	130	A + B	-	740-12-NOVIBRA

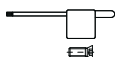

Chaque support est livré avec vis et clé.
 Jeder Halter wird mit Spannschraube(n) und Schlüssel geliefert.
 Screw(s) and key are included with each tool holder.

Porte-outils

Halter

Holders

740 / 730-D

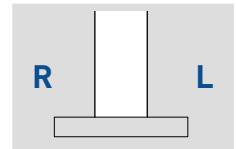
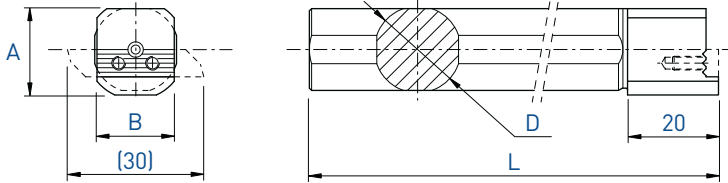

D	L	A	B	Art. N°
16	160	19	17	740/730-D16
19.05	160	19	17	740/730-D19.05
19.05	110	19	17	740/730-D19.05-S
20	160	19.5	17	740/730-D20
22	110	20	17	740/730-D22
25	200	22	17	740/730-D25
25.4	200	22	17	740/730-D25.4

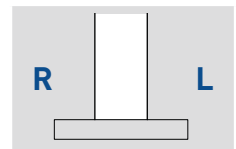
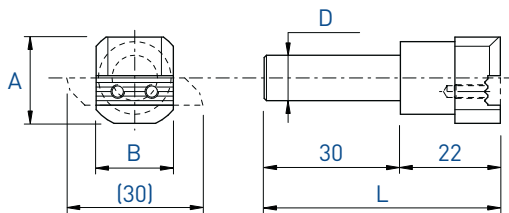

D	L	A	B	Art. N°
10	52	19	17	740/730-D10

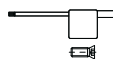

Chaque support est livré avec vis et clé.

Jeder Halter wird mit Spannschraube(n) und Schlüssel geliefert.

Screw(s) and key are included with each tool holder.

Porte-outils

Halter

Holder

Coupe à droite déportée

Versetztes Rechtsschneiden

Right cut off line

750RC

Utiliser des plaquettes type 751R
 WSP Typ 751R verwenden
 Use inserts type 751R

Voir pages 1.88 - 1.99
 Siehe Seiten 1.88 - 1.99
 See pages 1.88 - 1.99

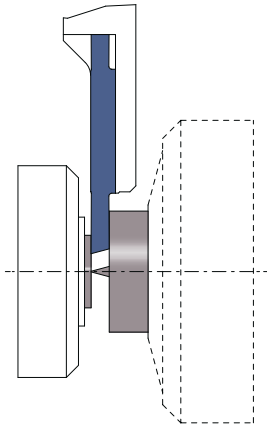
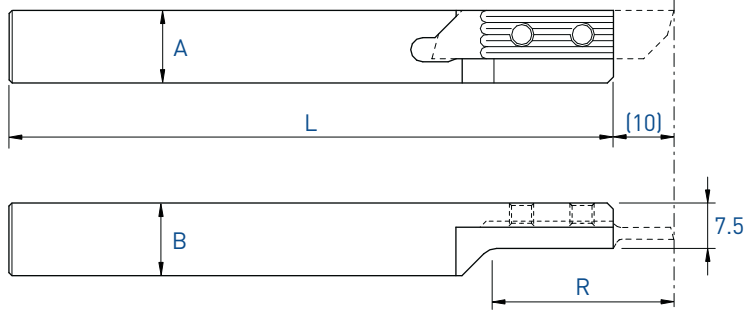

L (R)			
Coupe à droite déportée Versetztes Rechtsschneiden Right cut off line			
A x B	R	L	Art. N°
12 x 12	30	130	750RC-12
16 x 16	40	130	750RC-16

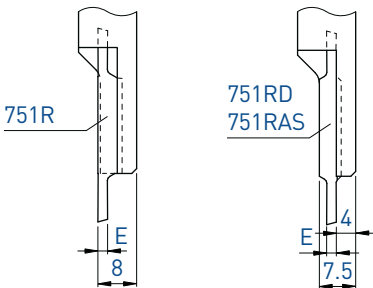

(p. 1.98 - 1.99)



Chaque support est livré avec vis et clé.
 Jeder Halter wird mit Spanschraube(n) und Schlüssel geliefert.
 Screw(s) and key are included with each tool holder.

Porte-outils

Halter

Holder

Coupe à gauche déportée

Versetztes Linksschneiden

Left cut off line

760LC

Utiliser des plaquettes type 761L
WSP Typ 761L verwenden
Use insets type 761L

Voir pages 1.88 - 1.94 + 1.98
Siehe Seiten 1.88 - 1.94 + 1.98
See pages 1.88 - 1.94 + 1.98

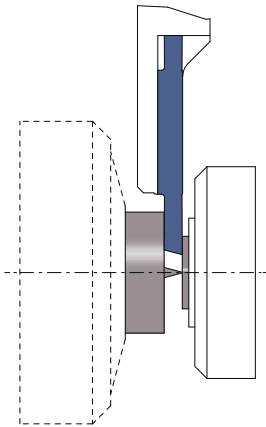
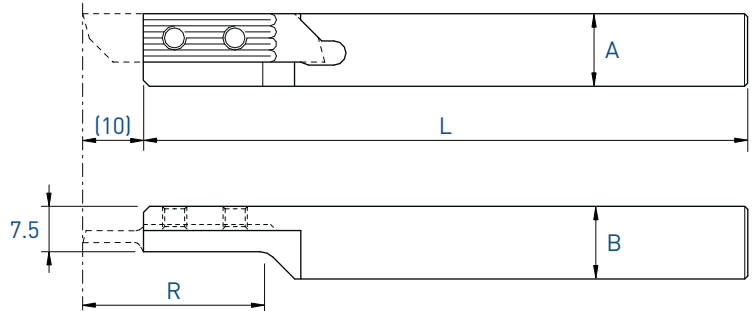

R (L)

Coupe à gauche déportée
Versetztes Linksschneiden
Left cut off line

A x B	R	L	Art. N°
16 x 16	40	130	760LC-16

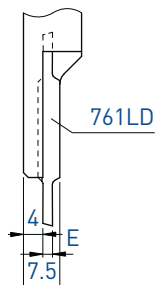
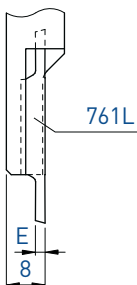

(p. 1.98)



Chaque support est livré avec vis et clé.
Jeder Halter wird mit Spannschraube(n) und Schlüssel geliefert.
Screw(s) and key are included with each tool holder.

R

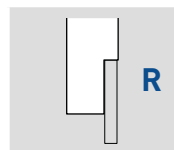
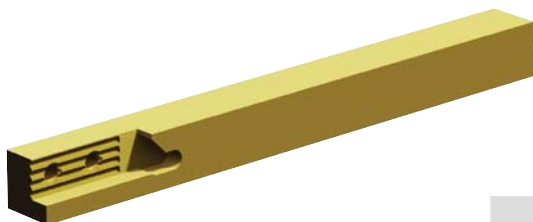
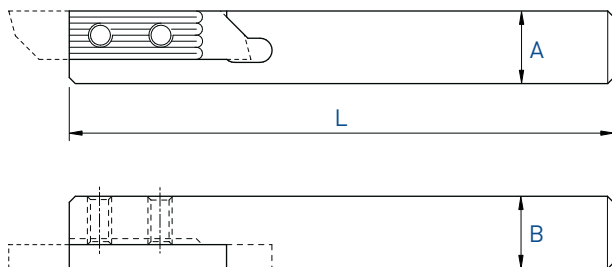

A x B	L	Serrage Spannsystem Clamping	Art. N°
10 x 10	115	A	760-10-NOVIBRA
12 x 12	130	A	760-12-NOVIBRA



Chaque support est livré avec vis et clé.
 Jeder Halter wird mit Spannschraube(n) und Schlüssel geliefert.
 Screw(s) and key are included with each tool holder.

Porte-outils

Halter

Holders

760 / 750-D10

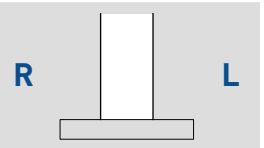
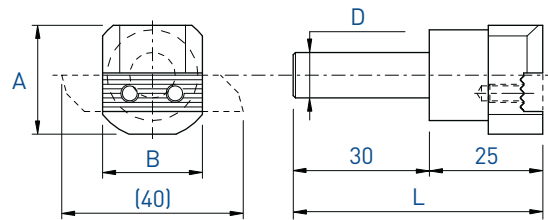

D	L	A	B	Art. N°
10	55	24	22	760/750-D10

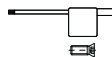

Chaque support est livré avec vis et clé.
 Jeder Halter wird mit Spannschraube(n) und Schlüssel geliefert.
 Screw(s) and key are included with each tool holder.

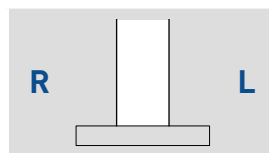
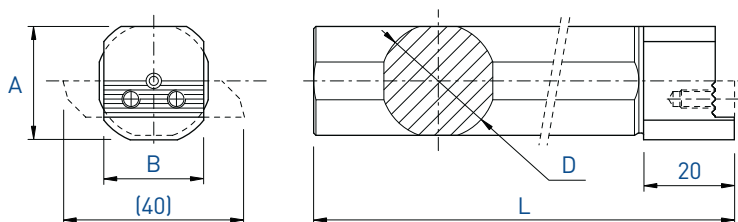

D	L	A	B	Art. N°
16	160	25	22	760/750-D16
19.05	160	25	22	760/750-D19.05
19.05	110	25	22	760/750-D19.05-S
20	160	25	22	760/750-D20
22	110	25	22	760/750-D22
25	200	25	22	760/750-D25
25.4	200	25	22	760/750-D25.4
25.4	125	25	22	760/750-D25.4-S

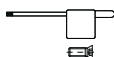

Chaque support est livré avec vis et clé.
 Jeder Halter wird mit Spannschraube(n) und Schlüssel geliefert.
 Screw(s) and key are included with each tool holder.

Porte-outils

Halter

Holders

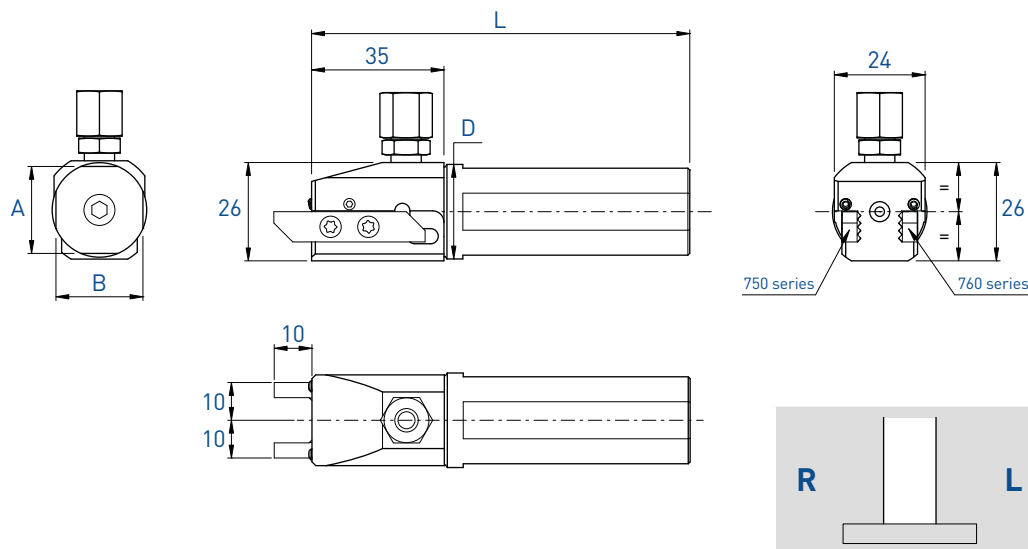

760 / 750-AX



D	L	A	B	Art. N°
25	100	23	23	760/750-AX-D25-JET
25.4	100	23	23	760/750-AX-D25.4-JET

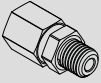

Chaque support est livré avec vis et clé.
 Jeder Halter wird mit Spannschraube(n)
 und Schlüssel geliefert.
 Screw(s) and key are included with each
 tool holder.

Pièces de rechange Ersatzteile Spare parts			Buse Düse Nozzle 
	Art. N°	Art. N°	Art. N°
760/750-AX	J-M8X1-D6	JB-M8X1	JJ-M3X6-D1.5

Porte-outils

Halter

Holders

L

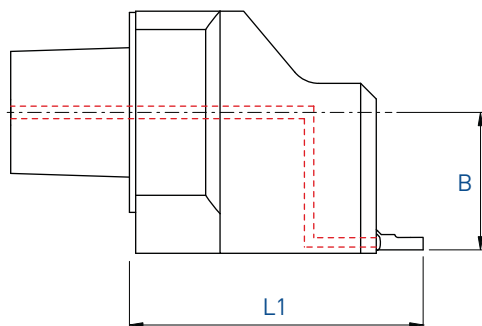
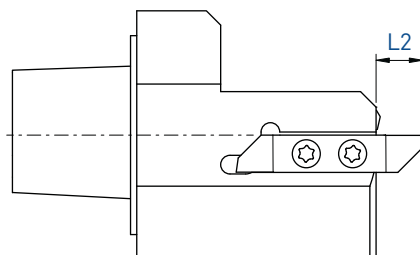
POLYGONAL INTERFACE
C4

Porte-outil Halter Holder	Plaquettes type WSP Typ Insert type	Pages Seiten Pages	L1	B	L2	Art. N°	Buse Düse Nozzle
							Art. N°
C4	750	> 1.78	62	27	10	C4-750-27062	JJ-M3X6-D1.5

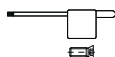

Chaque support est livré avec vis et clé.
Jeder Halter wird mit Spannschraube(n) und Schlüssel geliefert.
Screw(s) and key are included with each tool holder.

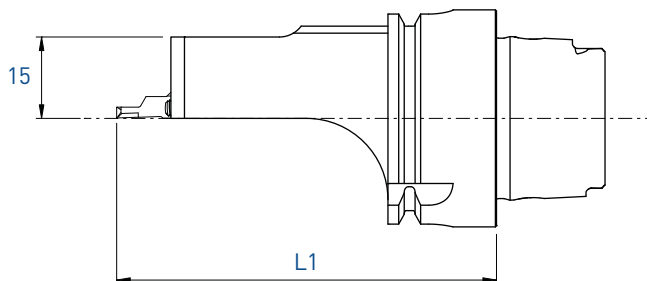
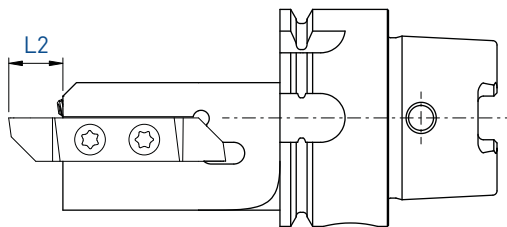

Utilisable sur toutes les machines avec broches HSK-T ou HSK-A

Auf allen Maschinen mit HSK-T oder HSK-A verwendbar

Applicable on all machines with HSK-T or HSK-A spindle

Plaquettes type WSP Typ Insert type	Pages Seiten Pages	L1	L2	Art. N°	Buse Düse Nozzle
					
740	> 1.32	65	7.5	HSK-T40-740-0065-JET	JJ-M3X6-D1.5
760	> 1.78	70	10	HSK-T40-760-0070-JET	JJ-M3X6-D1.5



Chaque support est livré avec vis et clé.
Jeder Halter wird mit Spannschraube(n) und Schlüssel geliefert.
Screw(s) and key are included with each tool holder.

Porte-outils pour usinage déporté

Halter für versetzte Bearbeitung

Holders for shifted machining

R

740Z / 760Z

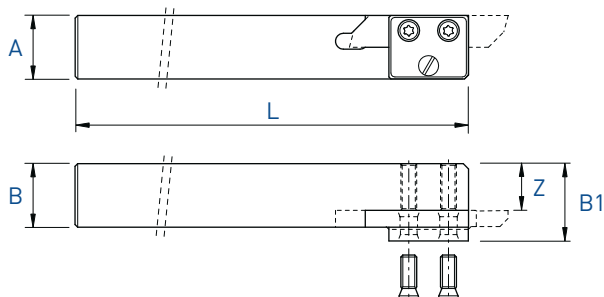
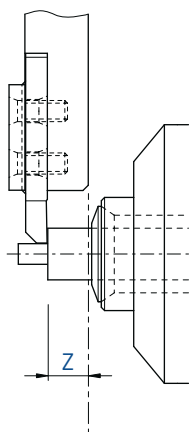
**740 Series**

A x B	L	Z	B1	Art. N°	Plaquettes type WSP Typ Inserts type	Pages Seiten Pages
12 x 12	130	9.5	14.5	740Z-12	741 - 747	> 1.32
16 x 16	130	13.5	18.5	740Z-16	741 - 747	> 1.32

760 Series

A x B	L	Z	B1	Art. N°	Plaquettes type WSP Typ Inserts type	Pages Seiten Pages
12 x 12	130	8	15	760Z-12	761 - 767	> 1.78
16 x 16	130	12	19	760Z-16	761 - 767	> 1.78

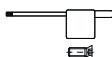

Chaque support est livré avec vis et clé.
Jeder Halter wird mit Spannschraube(n) und Schlüssel geliefert.
Screw(s) and key are included with each tool holder.

Coupe à droite
 Rechtsschneiden
 Right hand cut

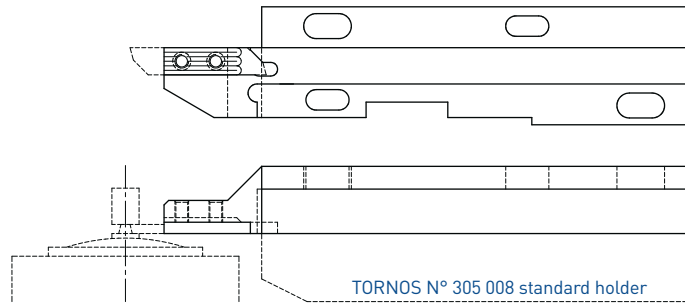

Art. N°	Plaquettes type WSP Typ Inserts type	Pages Seiten Pages
740-DECO10	741 - 747	> 1.32

Coupe à droite déportée
 Versetztes Rechtsschneiden
 Right cut off line

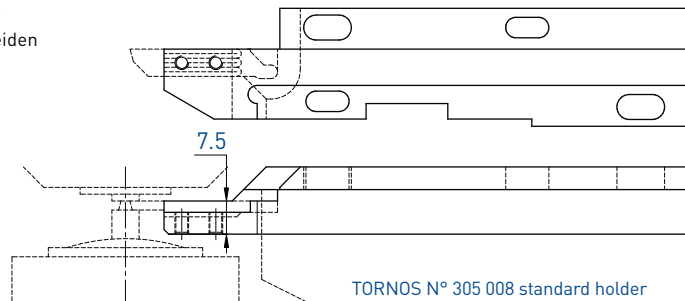

Art. N°	Plaquettes type WSP Typ Inserts type	Pages Seiten Pages
730R-DECO10	731R / 731N	1.39 - 1.45

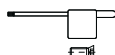

Chaque support est livré avec vis et clé.
 Jeder Halter wird mit Spannschraube(n) und Schlüssel geliefert.
 Screw(s) and key are included with each tool holder.

Porte-outils pour machine Tornos

Halter für Tornos Maschine

Holder for Tornos machine

R

DECO 7/10
EvoDECO 10

Pour le tronçonnage de petites pièces
Zum Abstechen von kleinen Werkstücken
For small parts parting off



Réglable en longueur
Längseinstellbar
Adjustable length

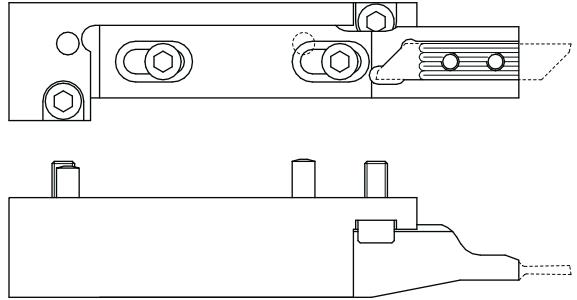

Art. N°	Plaquettes type WSP Typ Inserts type	Pages Seiten Pages
750R-DECO10	751R / 751N	1.88 - 1.99

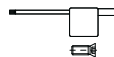
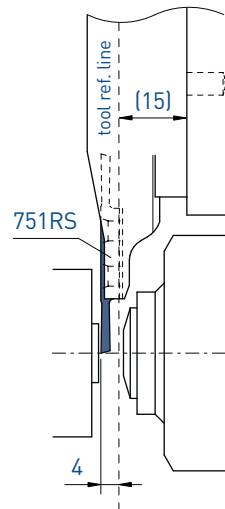
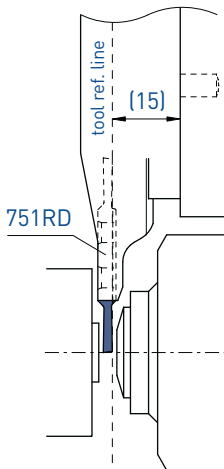

Chaque support est livré avec vis et clé.
Jeder Halter wird mit Spannschraube(n) und Schlüssel geliefert.
Screw(s) and key are included with each tool holder.

Porte-outils pour machine Tornos

Halter für Tornos Maschine

Holders for Tornos machine

L

DECO 7/10
EvoDECO 10

Coupe à gauche
Linksschneiden
Left hand cut

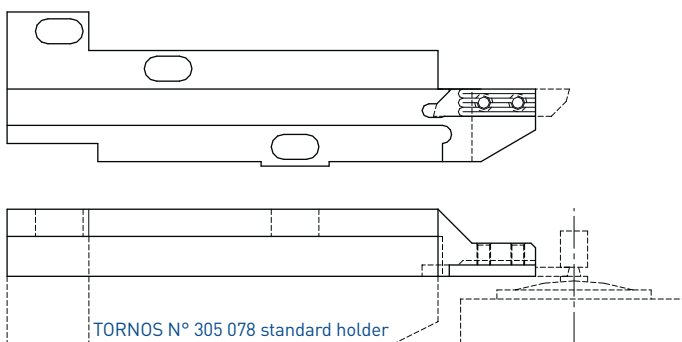

Art. N°	Plaquettes type WSP Typ Inserts type	Pages Seiten Pages
730-DECO10	731 - 737	> 1.32

Coupe à gauche déportée
Versetztes Linksschneiden
Left cut off line

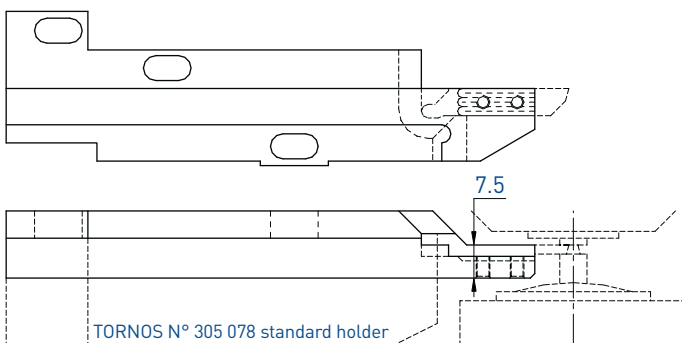

Art. N°	Plaquettes type WSP Typ Inserts type	Pages Seiten Pages
740L-DECO10	741L / 741N	1.39 - 1.45

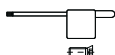

Chaque support est livré avec vis et clé.
Jeder Halter wird mit Spannschraub(en) und Schlüssel geliefert.
Screw(s) and key are included with each tool holder.

Porte-outils pour machine Tornos

Halter für Tornos Maschine

Holder for Tornos machine

L

DECO 7/10
EvoDECO 10

Pour le tronçonnage de petites pièces
Zum Abstechen von kleinen Werkstücken
For small parts parting off



Réglable en longueur
Längseinstellbar
Adjustable length

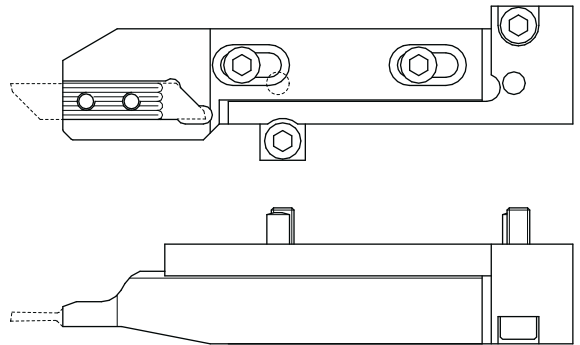

Art. N°	Plaquettes type WSP Typ Inserts type	Pages Seiten Pages
760L-DECO10	761L / 761N	1.88 - 1.98

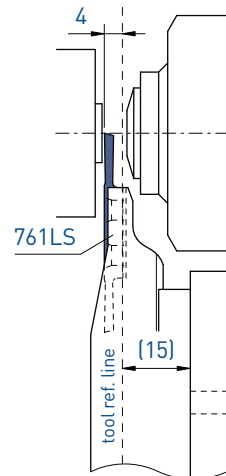
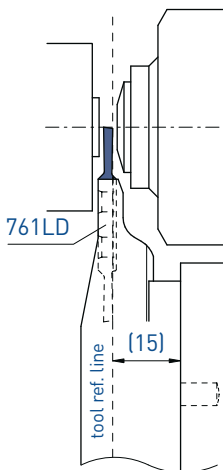

Chaque support est livré avec vis et clé.
Jeder Halter wird mit Spannschraubel(n) und Schlüssel geliefert.
Screw(s) and key are included with each tool holder.

Porte-outils pour machine Tornos

Halter für Tornos Maschine

Holders for Tornos machine

DECO 13
EvoDECO 16

Pour le tronçonnage de petites pièces
Zum Abstechen von kleinen Werkstücken
For small parts parting off

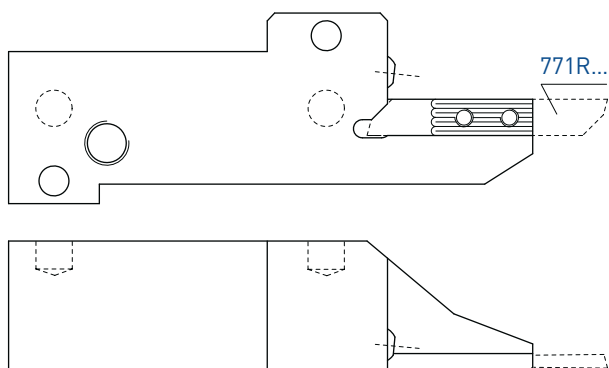

Art. N°	Plaquettes type WSP Typ Inserts type	Pages Seiten Pages
770R-DECO13	771R	1.137 - 1.140

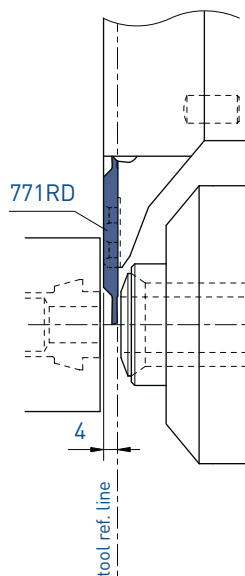
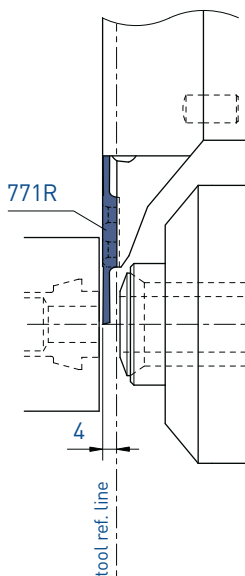

Chaque support est livré avec vis et clé.
Jeder Halter wird mit Spannschraube(n) und Schlüssel geliefert.
Screw(s) and key are included with each tool holder.

Porte-outils pour machine Tornos

Halter für Tornos Maschine

Holders for Tornos machine

DECO 20
EvoDECO 20/32

Pour le tronçonnage de petites pièces
Zum Abstechen von kleinen Werkstücken
For small parts parting off

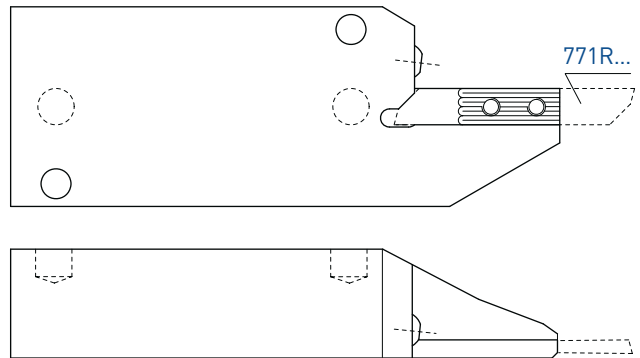

Art. N°	Plaquettes type WSP Typ Inserts type	Pages Seiten Pages
770R-DECO20	771R	1.137 - 1.140

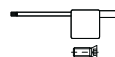
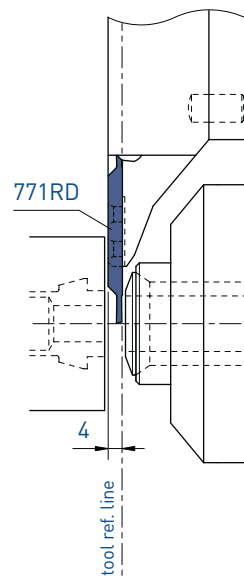
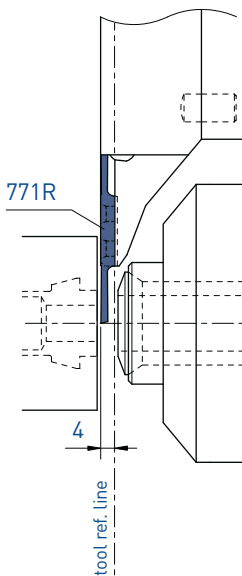

Chaque support est livré avec vis et clé.
Jeder Halter wird mit Spannschraube(n) und Schlüssel geliefert.
Screw(s) and key are included with each tool holder.

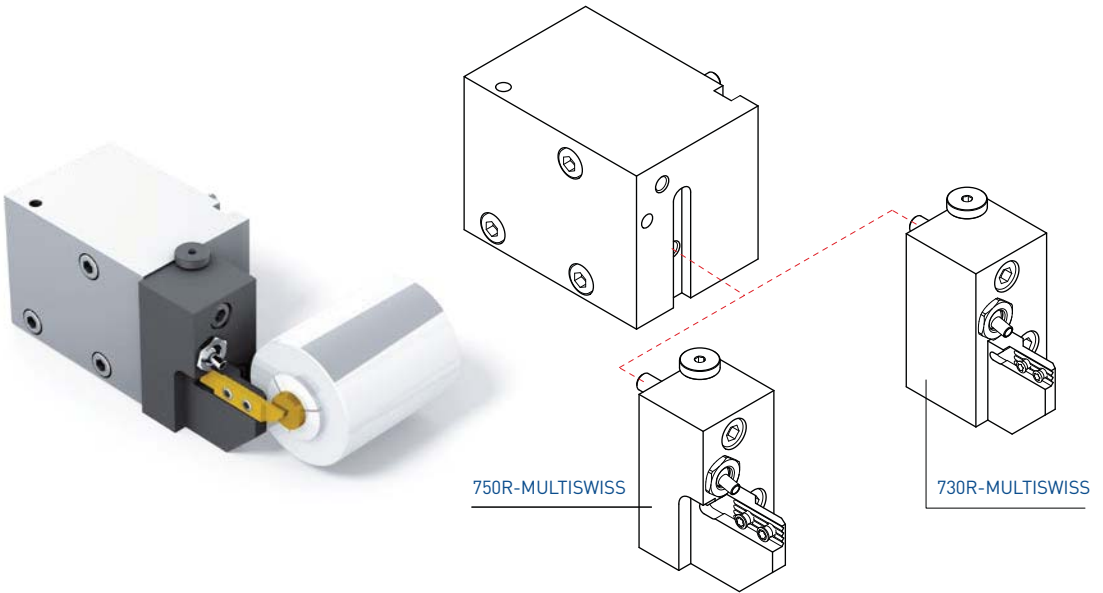
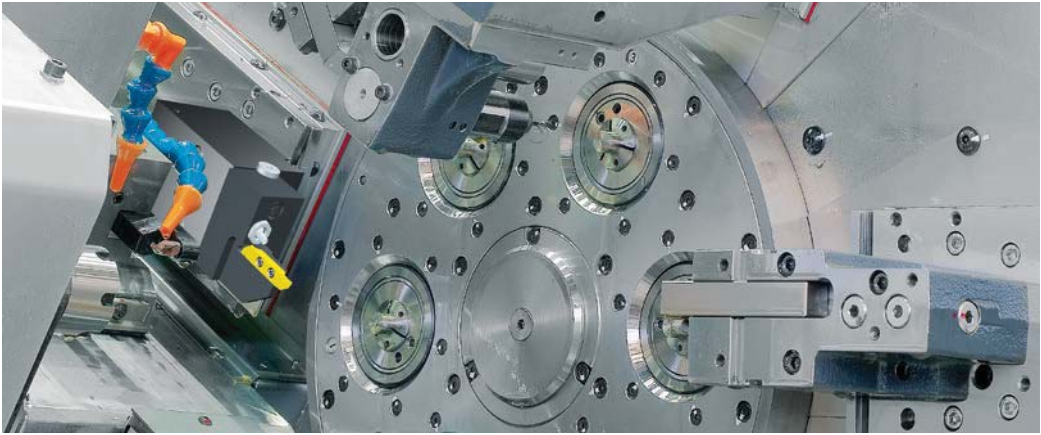

750R-MULTISWISS

730R-MULTISWISS

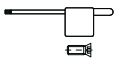

Chaque support est livré avec vis et clé.
 Jeder Halter wird mit Spannschraube(n) und Schlüssel geliefert.
 Screw(s) and key are included with each tool holder.

Art. N°	Plaquettes type WSP Typ Inserts type	Pages Seiten Pages
730R-MULTISWISS	731R / 731N	1.39 - 1.45
750R-MULTISWISS	751R / 751N	1.88 - 1.99

Porte-outils

Halter

Holder

Tornos AS 14
SAS 16

R

750RAS

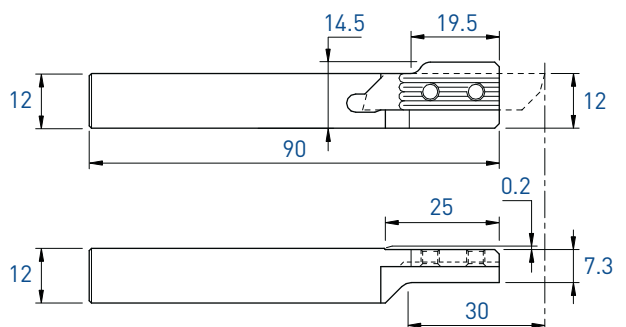

Art. N°	Plaquettes type WSP Typ Inserts type	Pages Seiten Pages
750RAS-12	751R	1.88 - 1.96

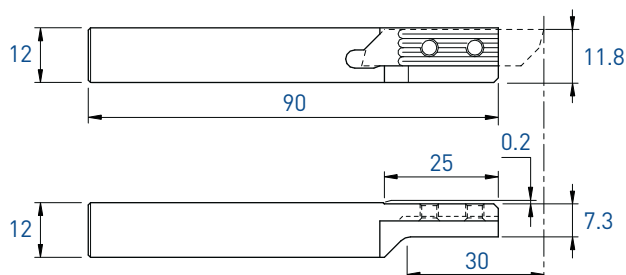

Art. N°	Plaquettes type WSP Typ Inserts type	Pages Seiten Pages
750RAS-12-H11.8	751R	1.88 - 1.96

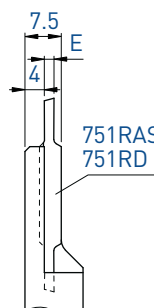
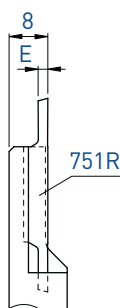
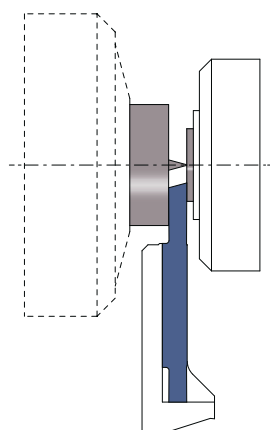

(p. 1.98 - 1.99)



Chaque support est livré avec vis et clé.
Jeder Halter wird mit Spannschraube(n) und Schlüssel geliefert.
Screw(s) and key are included with each tool holder.

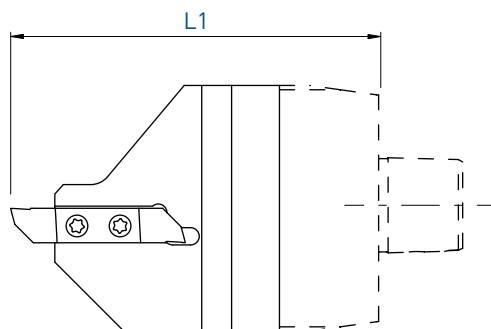

Compatibility Schütte

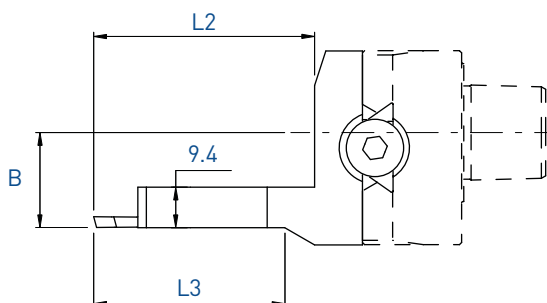
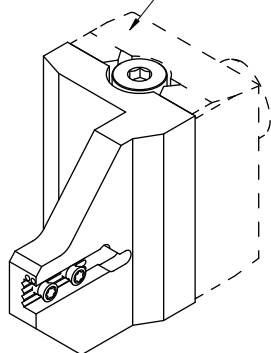

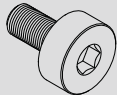

Plaquettes type WSP Typ Inserts type	Pages Seiten Pages	L1	B	L2	L3	Art. N°	Compatibility Schütte	
								Art. N°
761-767	> 1.78	86	22	51	44	DT20-760-JET	C3-75870949	V-M6X0.5-Ø14-L18
		83	27.5	48	-	DT30-760-JET	C4-75836783	

Vis et clés de rechange

Ersatzschrauben und Schlüssel

Spare screws and keys

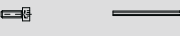
	Porte-outils Halter Holders	Serrage standard (A) Standard Spannsystem (A) Standard clamping system (A) 	Serrage type B Spannsystem Typ B Clamping system type B 			
710	710-6 / - NOVIBRA	V-M2.5X5.8-T8	C-T8	-	-	
	710-7 / - NOVIBRA	V-M2.5X6.5-T8				
	710-8 / - NOVIBRA	V-M2.5X7.8-T8				
	710-10 - 710-12					
720	720-7	V-M2.5X6.5-T8	C-T8	-	-	
	720-8 - 720-12	V-M2.5X7.8-T8				
730	730-7 / - JET / -NOVIBRA	V-M3X7-T8	C-T8	-	-	
	730-8 / -NOVIBRA			V-M2.5X7.8-T8	C-T8	
	730-10 - 730-20					
	730-DECO10					
	730R-DECO10					
730RC	V-M3X5.5-T8					
740	740-7 / -JET / -NOVIBRA	V-M3X7-T8	C-T8	-	-	
	740-8 / -NOVIBRA - 740-12 / -NOVIBRA			V-M2.5X7.8-T8	C-T8	
	740-16 - 740-20					
	740/730-D					
	740-C			V-M3X5.5-T8		
	740-DECO10			V-M3X7-T8		
	740L-DECO10			V-M3X9-T8		
740-Z						
	Porte-outils Halter Holders	Serrage standard (A) Standard Spannsystem (A) Standard clamping system (A) 	Serrage type B Spannsystem Typ B Clamping system type B 			
750	750-10 - 750-12 / -JET	V-M4X9-T15	C-T15	-	-	
	750-10-AB			V-M3X10-BN21	C-6P-2.0	
	750-12-AB			V-M3X8-BN11		
	750-12.7 - 750-14			V-M3X10-BN11	C-6P-2.5	
	750-16			V-M3X12-BN11		
	750-20			V-M3X16-BN11		
	750RAS - 750-RC			V-M4X7.3-T15		
750R-DECO10	V-M4X5.6-T15					
760	760-10 - 760-12 / -JET / -NOVIBRA / 760/750	V-M4X9-T15	C-T15	-	-	
	760-10-AB			V-M3X10-BN21	C-6P-2.0	
	760-12-AB			V-M3X8-BN11		
	760-12.7 - 760-14			V-M3X10-BN11	C-6P-2.5	
	760-16			V-M3X12-BN11		
	760-20			V-M3X16-BN11		
	760LC			V-M4X7.3-T15		
	760L-DECO10			V-M4X5.6-T15		
	760-Z			V-M4X12-T15		

MICRO-LINE

Fraises en bout de finition

Schlicht Schaftfräser

Finishing end mills

3336-HA / 3337-HA

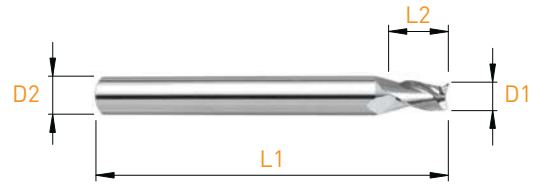
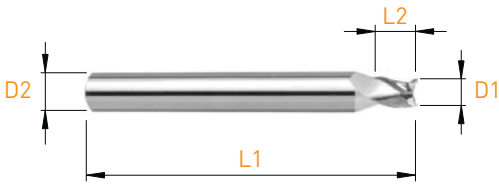

D1 h10	L2	D2 h6	L1	Art. N°	Z	TiAlN
1.50	3.00	6.00	51	3336-HA-1.5	■	■
1.80	3.00	6.00	51	3336-HA-1.8	■	■
2.00	3.00	6.00	51	3336-HA-2.0	■	■
2.50	3.00	6.00	51	3336-HA-2.5	■	■
2.80	4.00	6.00	51	3336-HA-2.8	■	■
3.00	4.00	6.00	51	3336-HA-3.0	■	■
3.50	4.00	6.00	51	3336-HA-3.5	■	■
3.80	5.00	6.00	54	3336-HA-3.8	■	■
4.00	5.00	6.00	54	3336-HA-4.0	■	■
4.50	5.00	6.00	54	3336-HA-4.5	■	■
4.80	6.00	6.00	54	3336-HA-4.8	■	■
5.00	6.00	6.00	54	3336-HA-5.0	■	■
5.50	7.00	6.00	54	3336-HA-5.5	■	■
5.80	7.00	6.00	54	3336-HA-5.8	■	■
6.00	7.00	6.00	54	3336-HA-6.0	■	■



D1 h10	L2	D2 h6	L1	Art. N°	Z	TiAlN
1.50	6.00	6.00	57	3337-HA-1.5	■	■
1.80	6.00	6.00	57	3337-HA-1.8	■	■
2.00	6.00	6.00	57	3337-HA-2.0	■	■
2.50	6.00	6.00	57	3337-HA-2.5	■	■
2.80	7.00	6.00	57	3337-HA-2.8	■	■
3.00	7.00	6.00	57	3337-HA-3.0	■	■
3.50	7.00	6.00	57	3337-HA-3.5	■	■
3.80	8.00	6.00	57	3337-HA-3.8	■	■
4.00	8.00	6.00	57	3337-HA-4.0	■	■
4.50	8.00	6.00	57	3337-HA-4.5	■	■
4.80	10.00	6.00	57	3337-HA-4.8	■	■
5.00	10.00	6.00	57	3337-HA-5.0	■	■
5.50	10.00	6.00	57	3337-HA-5.5	■	■
5.80	10.00	6.00	57	3337-HA-5.8	■	■
6.00	10.00	6.00	57	3337-HA-6.0	■	■