

# TOP-LINE

Tournage avant  
Vorwärts drehen  
Front turning

732 / 742

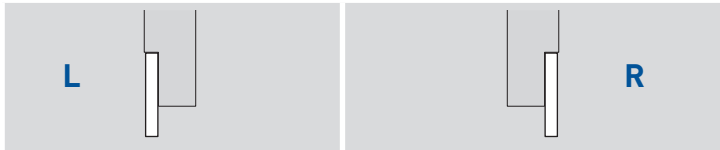
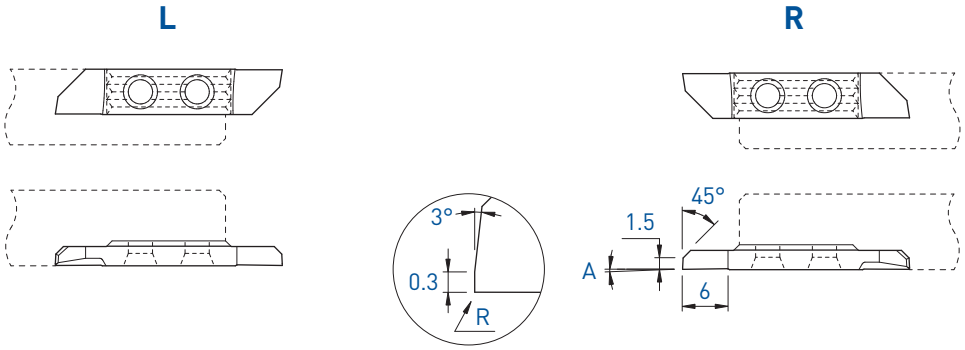

A	R	Art. N°	TiAlN	TiN	N (µk20)	HTA	HTiN	HN (µk10)	Art. N°	TiAlN	TiAlX	TiN	N (µk20)	HTA	HTiN	HN (µk10)
0°	0	732	■	■	■	■	■	■	742	■	■	■	■	■	■	■
2°	0	732-2°	■	■	■	■	□	■	742-2°	■	■	■	■	■	■	■

7XX-XX-B



Sur demande pour serrage type B, voir page 1.03  
Wahlweise mit B-Spannsystem, siehe Seite 1.03  
On request for B clamping system, see page 1.03

Tournage avant  
Vorwärts drehen  
Front turning

732PX / 742PX

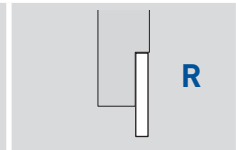
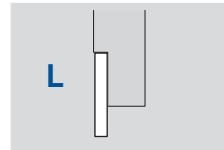
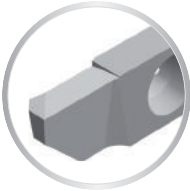
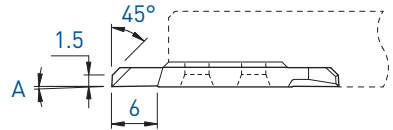
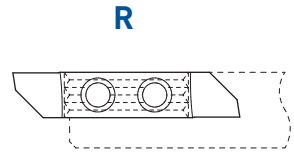
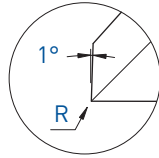
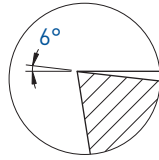
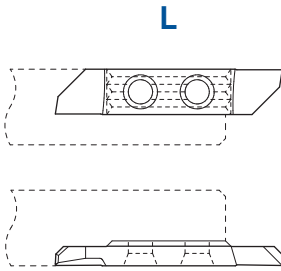

A	R	Art. N°	TiAlN	TiN	N [µk20]	Art. N°	TiAlN	TiN	N [µk20]
0°	0	732PX	■	■	■	742PX	■	■	■

7XX-XX-B

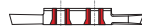

Sur demande pour serrage type B, voir page 1.03  
Wahlweise mit B-Spannsystem, siehe Seite 1.03  
On request for B clamping system, see page 1.03

■ = disponible / verfügbar / available  
□ = selon disponibilité du stock / jenach Lagerverfügbarkeit / depending on stock availability

# TOP-LINE

Tournage avant  
Vorwärts drehen  
Front turning

## 732X / 742X

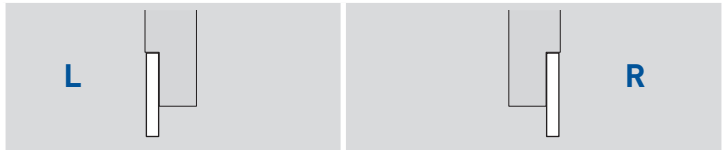
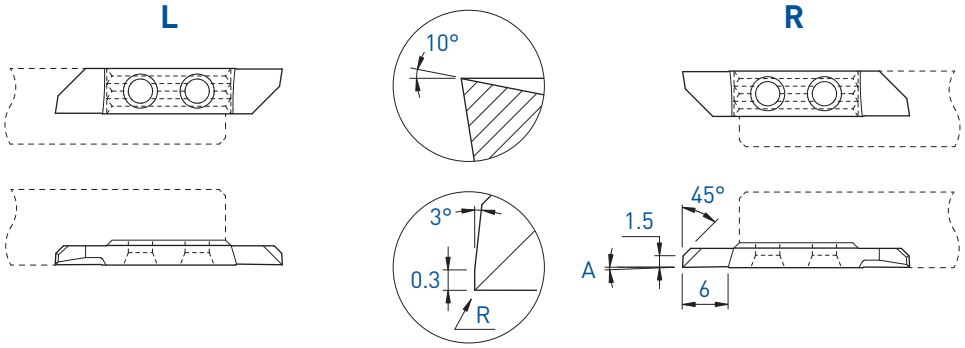

A	R	Art. N°	TiAlN	TiN	N (µk20)	HTA	HTiN	HN (µk10)	Art. N°	TiAlN	TiAlX	TiN	N (µk20)	HTA	HTiN	HN (µk10)
0°	0	732X	■	■	■	■	■	■	742X	■	■	■	■	■	■	■

7XX-XX-B



Sur demande pour serrage type B, voir page 1.03  
Wahlweise mit B-Spannsystem, siehe Seite 1.03  
On request for B clamping system, see page 1.03